



**KANOMAX**  
The Ultimate Measurements

**Q2 2020**  
PRODUCT CATALOG

# THE ULTIMATE MEASURING INSTRUMENTS

Handheld Anemometers | HVAC Testing Instruments | High Temperature Anemometer | Multi-Channel Anemometers  
Particle Counters | Cleanroom Monitoring System | Indoor Air Quality Monitors | Dust Monitors | Gas Monitors  
Sound Meters | Vibration Meters | Automotive Testing Instruments



[WWW.KANOMAX-USA.COM](http://WWW.KANOMAX-USA.COM)

## ■ Catalog Index

Airflow Transducer.....	Page 19
Amenity Manikin.....	Page 39
Cabin Leakage Tester.....	Page 40
Airflow Capture Hood.....	Page 11
Cleanroom Monitoring System.....	Pages 27-28
Dif-Kit Fume Hood Diagnostic Tools.....	Page 7
Dust Monitors.....	Pages 35-36
Duct Air Leakage Tester.....	Page 12
Flyash Sampler.....	Page 36
Gas Monitors.....	Page 31
Handheld Anemometers.....	Pages 3-8
Handheld Condensation Particle Counter (CPC).....	Page 25
Handheld Micromanometers.....	Pages 13-14
High Temperature Anemometer.....	Pages 15-16
IAQ Monitors.....	Pages 30-32
Multi-channel Anemometers.....	Pages 17-20
Odor Monitor.....	Page 32
Particle Counters.....	Pages 23-28
Piezobalance Dust Monitor.....	Page 35
Rotating Vane Digital Anemometer.....	Page 8
Steam Generator.....	Page 40
Sound Meter.....	Page 38
Vibration Meter.....	Page 38

# TABLE OF CONTENTS

Company Introduction & Services .....	Pages 1-2
Handheld Anemometers .....	Pages 3-8
HVAC Testing Instruments .....	Pages 9-14
High Temperature Anemometer .....	Pages 15-16
Multi-channel Airflow Measuring Instruments .....	Pages 17-20
Particle Counters .....	Pages 21-28
Indoor Air Quality Monitors .....	Pages 29-32
Dust Monitors .....	Pages 33-36
Sound Meters .....	Pages 37-38
Automotive Testing Instruments .....	Pages 39-40

# Kanomax Group

Since our inception over 85 years ago, Kanomax has been at the forefront of providing a broad range of precision measuring instruments for fluid mechanics research, environmental, aerosol research, particle measurement, and customized system applications. As a company that prides itself in technological innovation and providing quality products and services, we strive to maintain our unsurpassed reputation of supplying the very best testing solutions to the industrial and academic fields.

## Global Network

Our direct subsidiaries and Kanomax's affiliates and well-trained distributors worldwide are there to provide the most efficient support and service for you. Our global network is always listening to the voice of customers, like you, in order to keep providing the best measurement solutions possible.

- *Kanomax Holdings Inc. (New York, NY)*
- *Kanomax Corporation (Osaka, Japan)*
- *Kanomax Instrument Shenyang Inc. (China)*
- *Kanomax Holdings Shanghai Co., Ltd (China)*
- *Kanomax USA Inc. (Andover, NJ)*
- *Kanomax Japan Inc. (Osaka-Tokyo-Nagoya, Japan)*
- *MSI Tokyo (Tokyo, Japan)*
- *Kanomax FMT, Inc. (White Bear Lake, MN)*

## ISO Certification

Kanomax is an ISO 9001/ISO14001 certified company. Kanomax management and production procedures adhere to these international quality standards.



## KANOMAX PROVIDES OUTSTANDING SOLUTIONS

### Environmental Measurements

- HVAC Testing
- Indoor Air Quality
- Industrial Testing



### Aerosol/Particle Measurements

- Cleanroom Contamination Control
- Aerosol Research



### Fluid Measurements

- Fluid Mechanics



# Calibration Facility Ensures Accuracy and Repeatability

Kanomax fully understands service is an essential part of the total solution provided to our valued customers. Having already established a worldwide service network, we continuously strive to improve our support services.

For reliable measurements it is recommended that all instruments be calibrated on an annual basis. This ensures ongoing credibility and accuracy. Our calibration laboratory in New Jersey maintains the most accurate wind tunnel of its kind. Kanomax provides the highest quality of service available with one of the quickest turnaround times in the industry. Our service specialists are highly-trained and will calibrate your instruments to the highest standards.

Our lab certifies Kanomax products adhere to NIST standards.



High Velocity Wind Tunnel



Particle Generator



Open Jet Wind Tunnel

## FEATURED PRODUCTS



Handheld Anemometers



Airflow Capture Hood



Handheld Particle Counters



Remote Particle Sensor



# HANDHELD ANEMOMETERS

## Applications

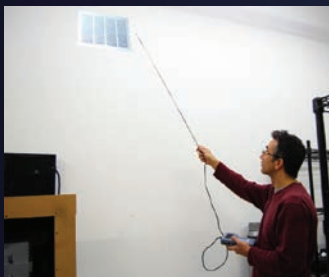

HVAC testing and balancing



Testing airflow rate of ventilation

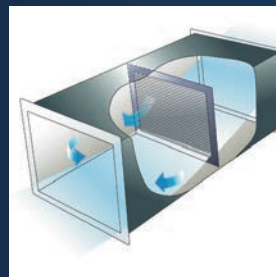

## Specifications

Model(s)	
Sensor Type	
Air Velocity Ranges	
	ft./min
	m/s
Resolution	
Accuracy	
Air Flow	CFM (ft <sup>3</sup> /min)
Temperature Ranges	
Accuracy	
Relative Humidity Ranges	
Accuracy	
Differential Pressure Ranges	
Accuracy	
Dimensions	
Main Unit	
Probe	
Weight	



### Anemomaster™ LITE

Palm-size and feather-weight standard hot-wire anemometer

- Compact and lightweight
- Data HOLD function
- Includes probe with 59 in (150 cm) cable, extension rod, 4 pcs. AA batteries, carrying case, and NIST Certificate



### Anemomaster™ Professional

Telescopic, articulating probe is designed for HVAC testing and balancing applications

- Simultaneous display of temperature and airflow or air velocity
- Telescopic, articulating probe
- Data HOLD function, record and recall MAX/MIN/AVG
- Store up to 1,500 measurements
- Data processing software allows real-time measuring and downloading data to PC
- Complete with telescopic probe with 79 in (200 cm) cable, Data processing software, USB cable, AC adapter, 6 pcs. AA batteries, carrying case, and NIST Certificate



### Climomaster™ Series

Multi-function hot-wire anemometer with detachable compatible probes

- Simultaneously measures and displays air velocity, flow rate, humidity, temperature, and differential pressure
- 8 interchangeable probes are available for various applications
- Smart probe technology: easy probe replacement without recalibration of the main unit
- Data HOLD function, record and recall MAX/MIN/AVG
- Store up to 20,000 measurements
- Data processing software allows real-time measuring and downloading of data to PC
- Includes probe, 79 in (200 cm) probe cable, 6 pcs. AA batteries, carrying case, and NIST Certificate



### Anemomaster™ Model 6810 Series

Rotating vane anemometer with high accuracy from 40 to 7800 fpm

- 2 vane head sizes are available for users' applications
- Industrial grade enclosure and metal vane probe
- Data HOLD, record and recall MAX/MIN
- Complete with metal vane sensor (choice of 2.75" or 1.00" diameter) with 5 ft long cable, extension rod with handle grip, flexible extension rod, 3 pcs. AA batteries, carrying case, and NIST Certificate

6006-DE	6036-0E/CE	6501	6812/6813/6815
Hot-wire	Hot-wire	Hot-wire	Rotating vane
2 to 3940	2 to 6000	2 to 9480	40 to 7800
0.01 to 20.0	0.01 to 30.0	0.01 to 50.0	0.2 to 40
0.01 m/s	0.01 m/s	0.01 m/s	0.01 m/s
+/- 5% of reading or 0.015 m/s whichever is greater	+/- 3% of reading or 0.015 m/s whichever is greater	+/- 2% of reading or 0.015 m/s whichever is greater	+/- 1% of reading
n/a	0 to 2,709,360	0 to 2,709,360	0 to 9,999
-4 to 158°F (-20 to 70°C)	-4 to 158°F (-20 to 70°C)	-4 to 158°F (-20 to 70°C)	-4 to 212°F (-20 to 100°C)
+/- 1°F (0.5°C)	+/- 1°F (0.5°C)	+/- 1°F (0.5°C)	+/- 0.5°F (0.3°C)
n/a	n/a	0.2 to 98.0% RH	0.5 to 95.0% RH
n/a	n/a	+/- 2% of reading	+/- 2% of reading
n/a	+/- 5.00 kPa *Option	+/- 5.00 kPa *Option	n/a
n/a	+/- (3% of reading +0.01) kPa	+/- (3% of reading +0.01) kPa	n/a
W2.4" x H4.7" x D1.2"	W3.4" x H7.4" x D1.6"	W3.4" x H7.4" x D1.6"	W3.3" x H6.3" x D1.5"
0.24" (6.1 mm) in diameter	0.24" (6.1 mm) in diameter	1.0 to 10 mm in diameter	Vane: 2.75" or 1.00" in diameter
0.4 lbs (180 g)	0.9 lbs (400 g)	0.9 lbs (400 g)	0.95 lbs (430 g)

# CLIMOMASTER™ 6501 SERIES



## Multi-function hot-wire anemometer with detachable compatible probes

### Features:

- Simultaneously measures and displays air velocity, flow rate, humidity, temperature, and differential pressure
- Airflow rate calculation based on registered duct size
- Now equipped with an automatic atmospheric pressure compensation function for precise airflow measurement
- Store up to 20,000 measurements
- 8 interchangeable probes are available for various applications
- Smart probe technology: easy probe replacement without recalibration of the main unit
- Includes probe, 79 in (200cm) probe connection cable, 6 pcs. AA batteries, carrying case, and NIST Certificate

Main Unit Specifications	
Air Velocity Ranges	2 to 9840 fpm (0.01 to 50.0 m/s) *Varies by probe
Accuracy	+/- 2% of reading or 0.015 m/s whichever is greater
Temperature Ranges	-4 to 158°F (-20 to 70°C)
Accuracy	+/- 1.0°F (0.5°C)
Relative Humidity Ranges	2.0 to 98.0%RH *Varies by probe
Accuracy	+/- 2.0%RH
Differential Pressure Ranges (Option)	+/- 5.00 kPa
Accuracy	+/- (3% of reading + 0.01) kPa
Interface	USB / RS232C (for print-out)
Datalogging	Up to 20,000 records
Analog Output (Option)	0 to 1 V
Power Supply	6 x AA Batteries or AC Adapter
Dimensions	W3.4" x H7.4" x D1.6" (88 x 188 x 41 mm)
Weight	0.9 lbs (400 g)

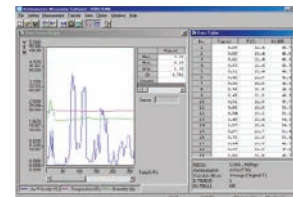

Optional data processing software allows real-time measuring and downloading data to your PC.

Probe Specifications								
Model	6531-2G	6541-2G	6561-2G	6542-2G	6533-2G	6543-2G	6551-2G	6552-2G
Probe Type	Uni-Directional	Uni-Directional	Uni-Directional	Omni-Directional	Omni-Directional	Omni-Directional	Mini-Spherical	Mini-Spherical
Air Velocity	2 to 6000 fpm	2 to 6000 fpm	2 to 9840 fpm	2 to 6000 fpm	2 to 1000 fpm	2 to 1000 fpm	2 to 6000 fpm	2 to 6000 fpm
Temperature	-4 to 158°F	-4 to 158°F	-4 to 158°F	-4 to 158°F	-4 to 158°F	-4 to 158°F	n/a	n/a
Relative Humidity	2.0 to 98.0 %RH	n/a	n/a	n/a	2.0 to 98.0 %RH	n/a	n/a	n/a

### Accessories

- 6501-CE Main Unit with Analog Output & Pressure Sensor
- 6531-04: Telescopic Extension Rod (Flex-Neck)
- 6531-05: Telescopic Extension Rod (Straight)
- 6531-06: 2m Probe Cable (also available in 5, 10, 20m)
- 6000-41: Data Processing Software (for Windows)
- 6000-62: Spare carrying case
- 6000-31: Printer Cable for DPU-S245
- 6000-61: Hands-free Case
- 6113-02: AC Adapter
- DPU-S245: Portable Thermal Printer
- TP-5RLPK: Rolled Printer Paper (1 roll)



6531-04



6531-05



6000-61



# ANEMOMASTER™ PROFESSIONAL MODEL 6036

Multi-function hot-wire Anemometer with telescopic, articulating probe

## Features:

- Simultaneous display of temperature and airflow or air velocity
- Telescopic probe measures air velocity and temperature in air ducts, vents, and small openings
- Data HOLD function, Record and recall MAX/MIN/AVG
- Store up to 1,500 measurements (Professional only)
- Data processing software allows real-time measuring and downloading data to your PC
- Includes telescopic probe with 79 in (200 cm) cable, Data processing software (Professional only), USB cable (Professional only), AC adapter, 6 pcs. AA batteries, carrying case and NIST Certificate

## Applications:

- HVAC Testing
- Facility Maintenance
- Critical Environment Certification
- IAQ Investigation



Telescopic probe is designed for HVAC testing and balancing applications

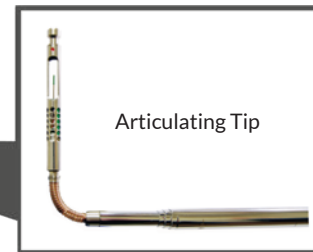

Specifications	
Model	Anemomaster™ Professional Model 6036
Probe Type	Telescopic and Articulating tip
Air Velocity Ranges	2 to 6000 fpm (0.01 to 30.0 m/s)
Accuracy	+/- 3% of reading or 0.015 m/s whichever is greater
Temperature Ranges	-4 to 158°F (-20 to 70°C)
Accuracy	+/- 1.0°F (0.5°)
Differential Pressure Ranges	+/- 5.00 kPa *Option
Accuracy	+/- 3% of reading +0.01 kPa
Interface - Digital	USB / (RS232C for print-out)
Datalogging	Up to 1500 records
Power Supply	6 x AA batteries or AC Adapter
Dimensions	W3.4" x H7.4" x D1.6"
Weight	0.9 lbs (400 g)

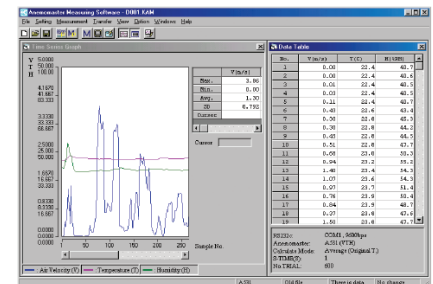

Windows 10 compatible software included

## Accessories

- \*6036-CE: Professional with Analog and Pressure Sensor
- 6000-31: Printer Cable for DPU-S245
- 6000-61: Hands-free Case
- 6000-62: Spare carrying case
- 6113-02: AC Adapter
- DPU-S245: Portable Thermal Printer
- TP-5RLPK: Rolled Printer Paper (1 roll)

## Theory of thermal (hot-wire) type Anemomaster™

The air velocity sensor is heated and temperature elevated (relative to the surrounding air) by means of control electronics. The temperature compensation sensor senses the ambient, or surrounding air temperature, and forces the velocity sensor to stay at a constant overheat above the ambient. The circuit forces the voltage to be equal by means of an operational amplifier. Air flowing past the sensor tends to cool the sensor, thus driving down its resistance. The amplifier responds by immediately delivering more power to the circuit to maintain voltage equilibrium. Delivered power is converted into electrical signals to display.

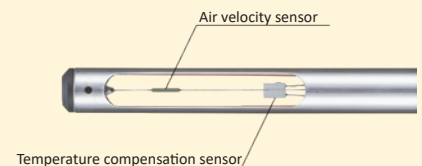

# ANEMOMASTER™ LITE



Palm-size and feather-weight standard hot-wire anemometer

### Features:

- Compact and lightweight
- Display switchable between m/s or ft/min (FPM) for air velocity and °F and °C for air temperature
- Average measurements over 1 or 5 seconds for air velocity
- Data HOLD function
- 4 pcs. AA batteries, extension rod, carrying case and NIST Certificate



Specifications	
Model	6006
Air Velocity Ranges	2 to 3940 fpm (0.01 to 20.0 m/s)
Accuracy	+/- 5% of reading or 0.015 m/s whichever is greater
Temperature Ranges	-4 to 158°F (-20 to 70°C)
Accuracy	+/- 1.0°F (0.5°C)
Power Supply	4 x AA Batteries or AC Adapter
Dimensions	W2.4" x H7.4" x D1.2"
Weight	0.4 lbs (180 g)

### Accessories

- 6112-03: Spare Extension Rod
- 6006-02: Spare Hard Carrying Case

## DIF-KIT TRACER GAS HARDWARE

Professional fume hood diagnostic tools

The ANSI/ASHRAE 110 test is a method of testing the performance of laboratory fume hoods. The Kanomax Dif-Kit is ideal for use in performing the Tracer Gas test in accordance with the ANSI/ASHRAE Standard 110-2016.

### Features:

- Diffuser is made to the design and specifications of Standard drawing #110-83M
- The internal critical orifice ensures a flow rate of 4 liters per minute.
- Thermal anemometer for face velocity testing
- Commercial fog machine for flow visualization



ASHRAE Standard 110-2016 Performance Testing

### ■ DIF-Kit



Specifications	
Model	Dif-Kit
Critical Orifice	4 liter per minute
Regulator	Dual Stage, Specialty Gas
Flow Meter	Calibrated 150 mm/200 psi, Glass Tube
Pressure Gauge	0 to 60 psi

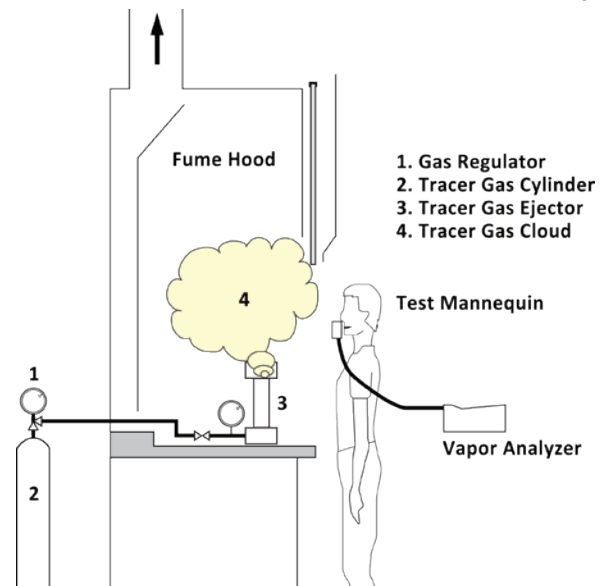

# ANEMOMASTER™ VANE MODEL 6810 SERIES



## Rotating vane digital anemometer

### Features:

- High accuracy from 40 to 7800 feet per minute
- 2 vane head sizes are available for users' applications
- Industrial grade enclosure and metal vane probe
- Large display with backlight
- Data HOLD, record and recall MAX/MIN
- Includes metal vane sensor (choice of 2.75" or 1.00" diameter) with 5 ft long cable, extension rod with handle grip, flexible extension rod, 3 pcs. AA batteries, carrying case, and NIST-traceable calibration certificate



1 inch Air Velocity Probe



6815 comes with HTP202

Specifications	6812		6813		6815	
<b>Model</b>	6812		6813		6815	
<b>Air Velocity Ranges</b>	2.75" Head	1.00" Head	2.75" Head	1.00" Head	2.75" Head	1.00" Head
ft/min	40 to 7800	300 to 6800	40 to 7800	300 to 6800	40 to 7800	300 to 6800
m/s	0.20 to 40.0	1.5 to 35.0	0.20 to 40.0	1.5 to 35.0	0.20 to 40.0	1.5 to 35.0
<b>Resolution</b>	1 FPM or 0.01 m/s		1 FPM or 0.01 m/s		1 FPM or 0.01 m/s	
<b>Air Flow CFM (ft3/min)</b>	0 to 9999		n/a		n/a	
<b>Temperature Ranges</b>	n/a		-4 to 212°F (-20 to 100°C)		-4 to 176°F (-20 to 80°C) *with HTP202	
<b>Accuracy</b>	n/a		+/- (0.3°C + 0.2% of reading in °C)		+/- (0.3°C + 0.2% of reading in °C)	
<b>Relative Humidity Ranges</b>	n/a		n/a		5.0 to 95.0% RH	
<b>Accuracy</b>	n/a		n/a		+/- 2.0% RH	
<b>Power Supply</b>	3 x AA Batteries		3 x AA Batteries		3 x AA Batteries	
<b>Main Unit Dimensions</b>	W3.2" x H6.5" x D1.5"		W3.2" x H6.5" x D1.5"		W3.2" x H6.5" x D1.5"	
<b>Weight</b>	0.95 lbs (430 g)		0.95 lbs (430 g)		1.1 lbs (500 g)	

Air Velocity Probes				Humidity & Temp. Probe		
<b>Model</b>	AP275	APT275	AP100	APT100	Model	HTP202
<b>Air Velocity</b>	2.75" Head		1.00" Head		<b>Relative Humidity</b>	
ft/min	40 to 7800		300 to 6890		<b>Range</b>	5.0 to 95.0% RH
m/s	0.20 to 40.0		1.5 to 35.0		<b>Resolution</b>	0.1% RH
<b>Accuracy</b>	+/- (1.0% reading + 1 digit)		+/- 0.50% FS + 0.75% reading + 1 digit		<b>Accuracy</b>	+/- 2.0% RH
<b>Temperature</b>					<b>Temperature</b>	
°F	n/a	-4 to 212	n/a	-4 to 212	°F	-4 to 176
°C	n/a	-20 to 100	n/a	-20 to 100	°C	-20 to 80
<b>Accuracy</b>	n/a	+/- (0.3°C + 0.2% of reading in °C)	n/a	+/- (0.3°C + 0.2% of reading in °C)	<b>Accuracy</b>	+/- (0.3°C + 0.2% of reading in °C)

## VANE AIR VELOCITY TRANSMITTERS

### Features:

- Transmitters specially designed for monitoring the Indoor Air Quality in the air conditioning, heating, and ventilation industries.
- Two versions available:  
AT400: Air Velocity Transmitter (2.75" and 1.00" probe options available)  
TAT420: Air Velocity & Temperature Transmitter (2.75" and 1.00" probe options available)
- Three separate power supplies 110 VAC 50/60 Hz, 220 VAC 50/60 Hz, and 10-30 VDC
- Three concurrent outputs for each measurement: 0-1 VDC, 0-5 VDC, and 4-20 mA DC
- Temperature range -4 to 212°F (-20 to 100°C)



# HVAC TESTING INSTRUMENTS





## SOLUTIONS FOR HVAC TESTING

Kanomax provides a complete line of products, from field test equipment to instruments used in the actual test and development of HVAC testing equipment. Rugged but accurate field instruments for the TAB technician, reliable anemometers and particle counters for development support, and precise monitoring instruments for laboratory environment control – we have it all.



Our products are becoming the first choice of HVAC professionals who operate test equipment on a day-to-day basis due to several factors. The innovative engineering of Kanomax products has resulted in unmatched ease of use, which has reduced the number of steps required to complete a task and decreased the level of effort required to utilize the equipment with maximum productivity. The same level of engineering that has maximized productivity through accessibility, has also brought about unmatched reliability so technicians can operate the equipment daily without having to worry about malfunctions or breakdowns.

## HVAC TESTING INSTRUMENTS BY APPLICATION

Duct and System Leakage Testing	Facilities Testing	Testing and Balancing
Duct Air Leakage Tester <i>Model 6900</i>	TABmaster Capture Hood <i>Models 6710 &amp; 6715</i>	TABmaster Capture Hood <i>Models 6710 &amp; 6715</i>
TABmaster Capture Hood <i>Models 6710 &amp; 6715</i>	Micromanometer <i>Model 6700-VG</i>	Micromanometer <i>Model 6700-VG</i>
Micromanometer <i>Model 6700-VG</i>	Handheld Micromanometer <i>Model 6850</i>	Kanomax Anemometers <i>*See Page 3</i>
Handheld Micromanometer <i>Model 6850</i>	Kanomax Anemometers <i>*See Page 3</i>	—

# TABMASTER™ CAPTURE HOOD MODELS 6710/6715



## A solution for airflow testing and balancing

The Kanomax TABmaster™ is the perfect tool for accurate supply and return airflow measurements. Interchangeable hoods make it easy to sample the air for any duct size. The unit is lightweight and easy to handle. The full color screen can be tilted so it's always at the optimal viewing angle regardless of height.

### Features:

- 23 to 2500 cfm (40 to 4250 m3/h) range
- Simultaneously measures and displays air flow, temperature and humidity
- Displays the direction of the airflow
- Store up to 8,000 measurements
- Advanced storage feature allows you to store multiple measurements under a single ID#
- Built-in back pressure compensation ensures accuracy for large volumetric flow measurements
- Removable handheld micromanometer with Bluetooth® wireless capability (Model 6715)
- Includes: standard hood, carrying case, PC communication cable, data processing software, user manual, and calibration certificate

### Applications:

- HVAC testing, adjusting and balancing
- Air volumetric flow measurements through registers, diffusers and grilles
- Direct readout at supply and return airflow
- Air velocity measurement in the duct
- Check filter fouling by measuring differential pressure

Specifications		
Model	6710	6715
Airflow Range	23 to 2500 CFM (40 to 4250 m3/h)	
Accuracy	+/- 3% of reading +/- 10 m3/h	
Resolution	1m3/h	
Air Velocity Range	n/a	0.15 to 40 m/s (Pitot), 0.15 to 15 m/s (Velocity Matrix)
Accuracy	n/a	±3% of readings ±0.05m/s
Resolution	n/a	0.1 m/s (>10.0m/s) 0.01m/s (<9.99m/s)
Temperature Range	32 to 122°F (0 to 50°C)	
Accuracy	+/- 1.0°F (0.5°C)	
Resolution	0.1°C	
Humidity Range	0 to 100% RH	
Accuracy	+/- 3.0% RH	
Resolution	0.1% RH	
Interface	USB	USB, Bluetooth®
Datalogging	Up to 3000 measurements	Up to 8000 measurements
Power Supply	AA batteries or AC adapter	
Hood Dimensions	2x2 ft (610x610 mm), 1x4 ft (305x1220 mm), 2x4 ft (610 x 1220 mm) 3x2 ft (915 x 610 mm), 3x3 ft (915x915 mm), 500x500mm	
Weight	7.9 lbs (3.6 kg)	

### Accessories

- |   |   |
|---|---|
| 6710-01: Spare Hood 2x2 ft (610x610mm)  | 6710-05: Spare Hood 3x3 ft (915x915mm)        |
| 6710-02: Spare Hood 2x4 ft (610x1220mm) | 6710-0X: Spare Hood 4x4 ft (1219x1219mm)      |
| 6710-03: Spare Hood 1x4 ft (305x1220mm) | 6710-07: Spare Hood Support Poles (for 2'x2') |
| 6710-04: Spare Hood 3x2 ft (915x610mm)  | 6710-08: Capture Hood Tri-pod Stand           |



Portable stand extends up to 6.5' from top to base



The Bluetooth® feature can send data to any Android-based device

# DUCT AIR LEAKAGE TESTER MODEL DALT 6900

## The most versatile duct and system tester

Designed to be simple to use, accurate, and extremely convenient, the Kanomax Duct Air Leakage Tester provides step-by-step test configuration and automated leakage testing based on the SMACNA HVAC Air Duct Leakage Test Manual, and is accurate to  $\pm 2.5\%$  of reading. Though built tough with an on-board, powerful motor, the DALT 6900 is very easy to transport on its pneumatic tires and leaves little to no footprint on the job site.

### Features:

- Tests up to 10,500 sq ft duct surface area
- Step-by-step test configuration and automated leakage testing
- Works for square and circular ducts as well as VAV systems

Specifications	
Model	6900
Air Velocity Ranges	Flow Grid: 2 to 360 CFM (36 to 640 m <sup>3</sup> /h) Nozzle: 2 to 21 CFM (4 to 36 m <sup>3</sup> /h)
Accuracy	2.5% of reading $\pm 0.1$ m <sup>3</sup> /h
Resolution	0.01 m <sup>3</sup> /h
Pressure Ranges	$\pm 10$ in.wg ( $\pm 2500$ Pa) Duct Static Pressure
Accuracy	1% of reading $\pm 1$ Pa
Resolution	0.1 Pa
Temperature Ranges	32 to 140 °F (0 to 60 °C)
Accuracy	$\pm 0.5$ °C
Resolution	0.1 °C
Absolute Pressure Ranges	20.6 to 38.3 in.Hg (70 to 130kPa)
Accuracy	2% of reading
Resolution	0.1kPa
Testing surface area	Up to 10500 sq. ft.
Interface	USB
Datalogging	Up to 1000 measurements
Weight	Approx. 75kg (165lbs)
Dimensions	W21 x D20 x H47 inches (54 x 50 x 120 mm)
Power Source	DALT 6900-0E: 110-120V, 1 Phase, 50/60Hz, 16A DALT 6900-1E: 220-240V, 1 Phase, 50/60Hz, 10A



## AUTOMATED LEAKAGE TESTING WITH EXPORTABLE REPORTS

Our Dust Air Leakage Tester has pre-loaded standards in its user interface, including the SMACNA standard. By following the simple step-by-step testing process you'll quickly get your test up and running with very little effort. Once tests are completed you can easily export the collected data in spreadsheet format to a USB flash drive to copy to your computer. This makes testing fast and generating accurate and reliable reports a breeze.



Built-in micromanometer with pre-programmed testing standards and motor speed controls

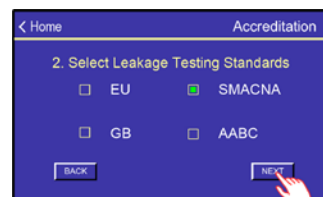
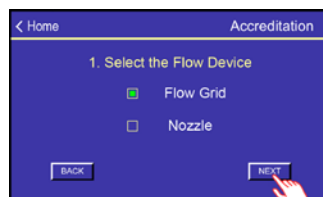

# MICROMANOMETER MODEL 6700-VG



## Smart micrometer for TAB professionals

The Kanomax Handheld Micromanometer - Model 6700-VG with Bluetooth® wireless capability takes airflow and pressure readings with a pitot tube or the optional velocity matrix. The matrix is a cross shaped grid, similar to the one in the base of the capture hood, that makes it possible to take face velocity readings and average velocity readings at multiple points simultaneously. The Bluetooth® feature can send data to your smartphone or any Android-based device.

### Features:

- Bluetooth connectivity
- Capable of taking traversal and grid readings
- Compatible with AirNAB digital data recording platform



Pitot tubes and Velocity Matrix are available from Kanomax

### Specifications

Model	6700-VG
Air Velocity Ranges	0.15 to 40 m/s (with pitot tube) 0.15 to 15 m/s (with velocity matrix)
Accuracy	±3% of readings ±0.05m/s
Pressure Ranges	-2500 to +2500 Pa
Accuracy	±1.5% of reading ±0.25 Pa
Temperature Ranges	0 to 50°C
Accuracy	+/- 1% of reading +1°C
Relative Humidity Ranges	0 to 100%RH
Accuracy	±3%RH (10~90%RH)
Interface	USB, Bluetooth®
Datalogging	8000 measurements
Power Supply	4 x AA Batteries or AC Adapter

## AIRNAB BY BUILDING START

### Bluetooth control and exceptional reports

AiRNAB is a digital recording platform that allows TAB technicians to sync their Kanomax Model 6715 Airflow Capture Hoods to their iOS-based mobile device via Bluetooth to start and stop measurements, as well as to automate reporting. With AiRNAB, technicians can ditch the old methods of scribbling notes and manually creating spreadsheet after spreadsheet. Instead, all of the readings data from the 6715 goes right into the user's AiRNAB account. From there the user can generate a custom-made report in just a few clicks.

- Log in and view air balance readings anytime.
- Track all recorded readings with usernames and date/time stamps.
- View a chronological TAB work audit trail.
- Generate final TAB reports within 24-48 hours of project completion, regardless of project size.
- Quickly turn around the final TAB report required for a certificate of occupancy



TO LEARN MORE CONTACT A  
KANOMAX REPRESENTATIVE:

[SALES@KANOMAX-USA.COM](mailto:SALES@KANOMAX-USA.COM)  
(800) 247-8889



# HANDHELD MICROMANOMETER MODEL 6850

## Smart micrometer for TAB professionals

The Kanomax Handheld Micromanometer - Model 6850 takes airflow and pressure readings with a pitot tube, making it easy to traverse ducts. With its ergonomic form factor, the 6850 is ideal for situations where technicians need their airflow meter to be portable yet durable. An optional attachable strap allows the meter to be hung from one's person or a nearby fixture to traverse ducts more easily.

### Features:

- Airflow (volumetric flow) measurement capabilities
- Duct traverse-capable with pitot tube (sold separately)

Specifications	
Model	6850
Airflow Ranges	10 to 60 m/s
Accuracy	±1.5% of reading
Resolution	0.001 m/s
Pressure Ranges	-2500 to +2500 Pa
Accuracy	±0.5% of reading ±1 Pa
Resolution	0.1 Pa
Operating Temperature	0 to 60°C
Storage Temperature	-20 to 70°C (no condensation)
Interface	USB
Datalogging	10000 measurements
Power Supply	4 x AA Batteries or AC Adapter
Weight	360g (0.79 lbs)
Dimensions	W85 x H200 x D40 mm

### Accessories

- 6700-01: Velocity-Grid (\*only for use with 6710/6715)
- 6700-02: Pitot tube (5/16" x 8-5/8")
- 6700-03: Pitot tube (5/16" x 12-5/8")
- 6700-04: Pitot tube (5/16" x 18-5/8")
- 6700-08: Static Pressure Probe



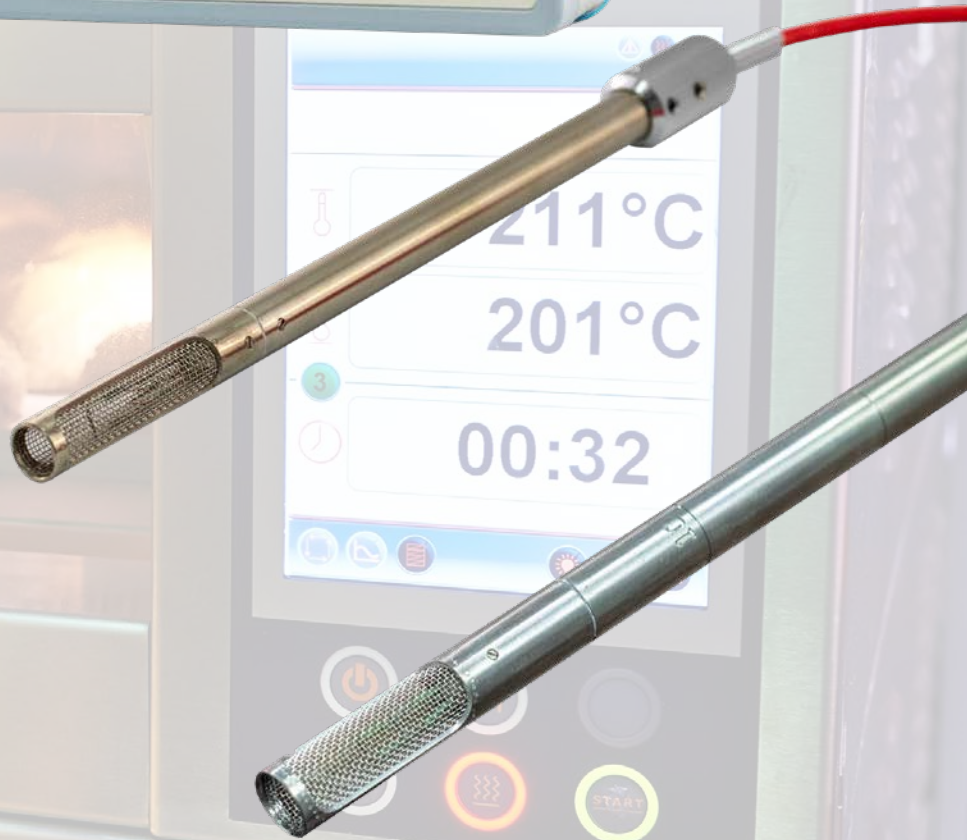

# HIGH TEMPERATURE ANEMOMETER

# ANEMOMASTER™ MODEL 6162



## High temperature anemometer

### Features:

- Air velocity and temperature measurements in environments up to 932°F (500°C)
- Record and recall MAX/MIN/AVG, Timing graph display
- Store up to 999 measurements
- RS232C interface, analog output, and remote control terminal equipped
- Includes shoulder strap, AC adapter, 2 pcs. analog output cable, and 6 pcs. C cell batteries



To perform high temperature measurements the Model 6162 must be used with one of these high temperature probes (0203, 0204 or 0205)

- The Model 0203 includes probe with 4.9 ft (1.5 m) cable, 5m probe connection cable, probe case, and NIST Certificate
- The Model 0204 includes probe with 7.6 ft (2.3 m) cable, 10m probe connection cable, probe case, and NIST Certificate
- The Model 0205 includes probe with 7.6 ft (2.3 m) cable, 10m probe connection cable, probe case, and NIST Certificate

Probe Specifications		0203	0204/0205
Model			
Air Velocity Measuring Range	Temp. Range		
	32 to 212°F	40 to 9840 fpm (0.2 to 50.0 m/s)	
	212 to 392°F	80 to 9840 fpm (0.4 to 50.0 m/s)	
	392 to 572°F	n/a	138 to 9840 fpm (0.7 to 50.0 m/s)
	572 to 752°F	n/a	197 to 9840 fpm (1.0 to 50.0 m/s)
	Accuracy	+/- 3% Full Scale	
Temperature Measuring Range		32 to 392°F (0 to 200°C)	32 to 932°F (0 to 500°C)
	Accuracy	+/- 1% of reading	
Dimensions / Weight		ø 11 x 200 mm (ø 0.4" x 7.8") 0.4 lbs (200 g)	<b>0204</b> ø 14 x 1000 mm (ø 0.6" x 39.4") 1.1 lbs (500 g) <b>0205</b> ø 14 x 500 mm (ø 0.6" x 19.7") 0.4 lbs (200 g)
	Probe Cables		Teflon Coating
	Heat-resistance		392°F (200°C)
Extension Cable			Vinyl Coating
	Heat-resistance		176°F (80°C)

Main Unit Specifications	
Model	6162
Air Velocity Ranges	Varies by Probe, see below for Probe Specifications
Accuracy	+/- 3% of Full Scale
Temperature Ranges	Varies by Probe, see below for Probe Specifications
Accuracy	+/- 1% of reading +1°C
Interface	RS232C
Datalogging	999 measurements
Analog Output	0 to 1 V
Remote Terminal	START/STOP Key
Power Supply	6 x C cell Batteries or AC Adapter
Dimensions	W8.7" x H3.3" x D5.9"
Weight	4.0 lbs (1.8 kg)

### Accessories

- 0203: Probe for Middle Temperature
- 0204: Probe for High Temperature (Long)
- 0205: Probe for High Temperature (Short)
- 6162-03: Extension Rod for 0203
- 6162-04: Extension Rod for 0204/0205
- 6162-05: Communication Cable to PC
- 6162-06: Probe Compression Fitting for 0204/0205
- 6162-07: Probe Compression Fitting for 0203
- 6000-41: Data Processing Software
- 6511-09: Printer Cable for DPU-S245
- DPU-S245: Portable Thermal Printer
- TP-5RLPK: Rolled Printer Paper (1 roll)

\*Optional probe cable lengths up to 40m are available

### Probe Dimensions

\*Length in mm      \*Heat Resistance

#### MODEL 0203

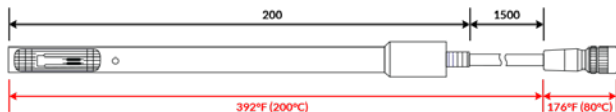

#### Extension Rod for 0203 \*Optional

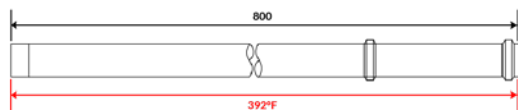

#### Entire Length

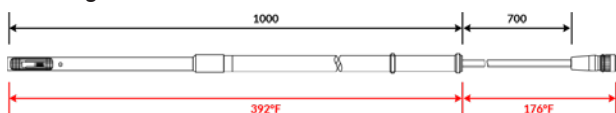

#### Probe Cable

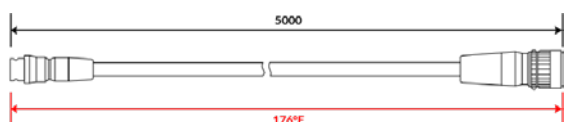

#### MODEL 0204

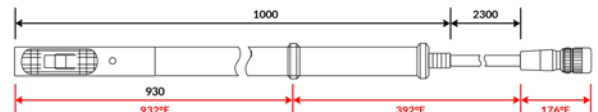

#### Extension Rod for 0204 \*Optional

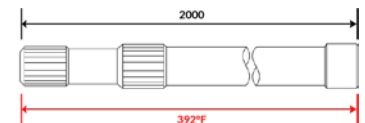

#### Entire Length

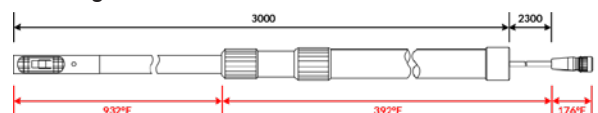

#### MODEL 0205

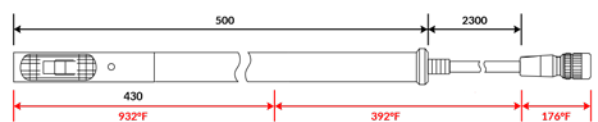

# MULTI-CHANNEL AIRFLOW MEASURING INSTRUMENTS

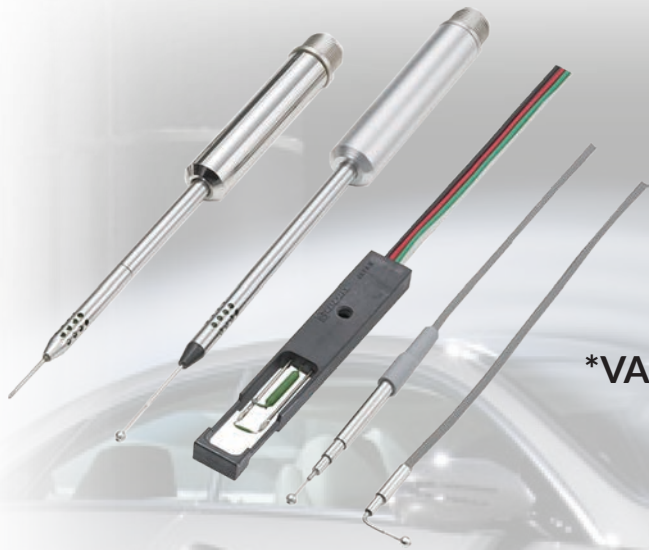

**\*VARIETY OF PROBES FOR MANY APPLICATIONS**

## Main Unit Specifications

Model
Probe Compatible
Air Velocity Ranges
Temperature Ranges
Relative Humidity Ranges
PC Communication
Interface
Analog Output
Power Supply
Dimensions
Weight



### Airflow Transducer Model 6332 / 6332D

Compact design Airflow Transducer, fits into small spaces

- 10 interchangeable probes are available for various applications
- Easy probe replacement without recalibration of the main unit
- Selectable output options: 0 to 5 V or 4 to 20 mA



### 4-Channel Anemomaster™ Model 1570

Compact design 4-channel unit with compatible probes

- 10 interchangeable probes are available for various multi-channel applications
- Simultaneously measurements of 4 channels of air velocity
- Software allows real-time measurements of air velocity and airflow in 4 channels
- The Model 1570 includes data processing software, RS232C cable, power cable, and 2 pcs. fuse



### Multi-Channel Anemomaster™ Model 1550 / 1560

Up to 320 points multi-measurements system with a variety of probes

- System can be scaled up with modules and probes
- 3 types of probes are available
- 4 types of modules are available
- The chassis may be cascaded up to 5 units via RS232C
- Multi-channel Anemomaster includes RS232C cable, printer cable, power cable, and 2 pcs. fuse

6332/6332D	1570	1550 / 1560
V Probe	V Probe	V Probe / VT Probe / VTH Probe
20 to 9840 fpm (0.10 to 50.0 m/s)	20 to 9840 fpm (0.10 to 50.0 m/s)	20 to 9840 fpm (0.10 to 50.0 m/s)
n/a	n/a	32 to 212°F (0 to 100°C)
n/a	n/a	5.0 to 95.0% RH
n/a	Data Processing Software	Data Processing Software
n/a	RS232C	RS232C, Centronics, GP-IB
DC 4 to 20mA or DC 0 to 5V	0 to 5 V	0 to 5 V
DC or AC	AC	AC
W3.1" x H5.0" x D1.2"	W10.2" x H2.8" x D7.9"	Model 1550: W19.6" x H5.5" x D16.9" Model 1560: W8.9" x H5.5" x D12.8"
0.7 lbs (320 g)	5.7 lbs (2.6 kg)	Model 1550: 22 lbs (10 kg) Model 1560: 11 lbs (5 kg)

# AIRFLOW TRANSDUCER MODEL 6332 / 6332D



## Features:

- Smart probe technology: easy probe replacement without recalibration of the main unit
- Selectable output options: 0 to 5 V or 4 to 20 mA

Main Unit Specifications		
Model	6332	6332D
Display	—	○
Air Velocity Ranges	Varies by probe, See below for Probe Specifications	
Accuracy	+/- 3% of reading	
Analog Output	DC 4 to 20mA or DC 0 to 5V	
Power Consumption	Approx. 2.0 W	
Power Supply	DC 12 to 24V or AC 80 to 240V	
Dimensions	W3.1" x H5.0" x D1.2"	
Weight	0.7 lbs (320 g)	

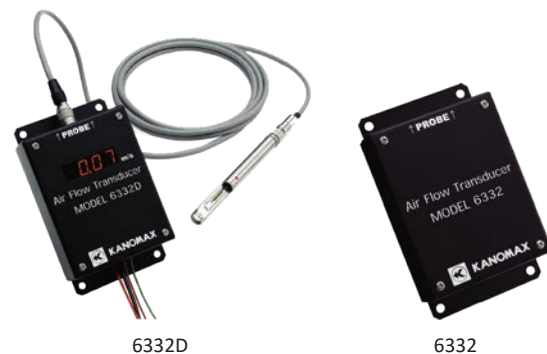

# 4-CHANNEL ANEMOMASTER™ MODEL 1570

## Features:





- Simultaneous measurements of 4 channels of air velocity; easy to switch over each channel display
- Software allows real-time measurements of air velocity and airflow in 4 channels
- The Model 1570 includes data processing software, RS232C cable, power cable, and 2 pc. fuse





Main Unit Specifications	
Model	1570
Air Velocity Ranges	Varies by probe, See below for Probe Specifications
Resolution	0.01 m/s
Interface	RS232C
Analog Output	0 to 5V
Power Supply	AC 85 to 265V
Dimensions	W10.2" x H2.8" x D7.9"
Weight	5.7 lbs (2.6 kg)



## Probes Compatible with Models 1550, 1560, 1570 and 6332/6332D

### Air Velocity Probes (V Probes)

Probe Specifications				
Model	0962-00	0963-00	0965-00/-01	0965-09/10
Probe Type	Uni-Directional	Uni-Directional	Omni-Directional	Omni-Directional
Air Velocity	20 to 9840 fpm (0.10 to 50.0 m/s)	20 to 9840 fpm (0.10 to 50.0 m/s)	20 to 4920 fpm (0.10 to 25.0 m/s)	20 to 9840 fpm (0.10 to 50.0 m/s)

Probe Specifications				
	Miniature Probe with built-in temperature compensation		Miniature Probe with independent temperature compensation	
	Air Velocity Sensor Temperature Compensation Sensor		Air Velocity Sensor Temperature Compensation Sensor	
Model	0965-03	0965-04	0965-07	0965-08
Probe Type	Omni-Directional	Omni-Directional	Omni-Directional	Omni-Directional
Air Velocity	20 to 4920 fpm (0.10 to 25.0 m/s)	20 to 4920 fpm (0.10 to 25.0 m/s)	20 to 4920 fpm (0.10 to 25.0 m/s)	20 to 4920 fpm (0.10 to 25.0 m/s)

# MULTI-CHANNEL ANEMOMASTER™ MODEL 1550/1560



Create monitoring systems with up to 64 measuring points

## Features:

- The multi-channel Anemomaster is composed of chassis, module, and probe. The Model 1550 (chassis) holds 16 modules and the Model 1560 holds 6 modules
- The chassis may be cascaded up to 5 units (5 units of Model 1550 can hold 320 channels of air velocity sensors)
- 3 types of probes are available:  
Air velocity probe (V probe)  
Air velocity / Temperature probe (VT probe)  
Air Velocity / Temperature / Humidity probe (VTH probe)
- 4 types of modules are available:  
4 channel air velocity module  
2 channel air velocity / temperature module  
1 channel air velocity / temperature / humidity module  
Analog output module
- Multi-channel Anemomaster includes RS232C cable, printer cable, power cable, and 2 pcs. fuse



## Accessories





- 1500-01: RS232C for Cascade Connection
- 1500-03: Ring Guards for Probe Protection
- 1504-04: Cable for V module (10m)\*
- 1511-01: Cable for VT Module (10m)\*
- 1512-01: Cable for VTH Module (10m)\*
- S620-00: Data Processing Software (for Windows)

\*Additional cable lengths available





Main Unit Specifications		
Model	1550	1560
Air Velocity Ranges	Varies by Probe, See below for Probe Specifications	
Resolution	0.01 m/s	
Temperature Ranges	Varies by Probe, See below for Probe Specifications	
Resolution	0.1°C	
Relative Humidity Ranges	Varies by Probe, See below for Probe Specifications	
Resolution	0.1% RH	
Interface	RS232C for PC Connection	
	RS232C for Cascade *Option	
	Centronics for Printer Output	
	GP-IB *Option	
Analog Output	0 to 5 V *Option with D/A Module	
Power Supply	AC Adapter	
Dimensions	W19.6" x H5.5" x D16.9"	W8.9" x H5.5" x D12.8"
Weight	22 lbs (10 kg)	11 lbs (5 kg)

## Probes Compatible with Models 1550, 1560, 1570

### Air Velocity Temperature Humidity Probes (VT / VTH Probes)

Probe Specifications					
Model	0962-21	0963-21	0965-21	0963-31	0965-31
Probe Type	Uni-Directional	Uni-Directional	Omni-Directional	Uni-Directional	Omni-Directional
Air Velocity	20 to 9840 fpm (0.10 to 50.0 m/s)	20 to 9840 fpm (0.10 to 50.0 m/s)	20 to 9840 fpm (0.10 to 50.0 m/s)	20 to 9840 fpm (0.10 to 50.0 m/s)	20 to 9840 fpm (0.10 to 50.0 m/s)
Temperature Ranges	32 to 212°F (0 to 100°C)	32 to 212°F (0 to 100°C)	32 to 212°F (0 to 100°C)	32 to 212°F (0 to 100°C)	32 to 212°F (0 to 100°C)
Relative Humidity Ranges	n/a	n/a	n/a	5.0 to 95.0% RH	5.0 to 95.0% RH

### Modules

Specifications				
Model	1504 V Module	1511 VT Module	1512 VTH Module	1510 D/A Module
Module Type	Air Velocity	Air Velocity, Temp.	Air Velocity, Temp., Humidity	Analog Output
# of Channels	4	2	1	1



Model 1560 has 6 slots for modules



# PARTICLE COUNTERS

## ■ Applications



Cleanroom Certification



Indoor Air Quality Investigation





### Handheld Particle Counter Model 3888

Simple and easy-to-use, affordable handheld particle counter

- Simultaneously measures and displays 3 particle sizes
- 4.3 inch color touchscreen
- Store up to 10,000 measurements
- Includes data processing software, USB cable, li-ion rechargeable batteries, AC adapter, and calibration certificate



### Handheld Particle Counter Model 3889

Lightweight handheld particle counter with environmental sensors

- Simultaneously measures and displays 6 particle sizes
- 4.3 inch color touchscreen
- Temperature and humidity measurements with optional probe
- Store up to 10,000 measurements
- PC interface with USB and optional software for real-time monitoring with timing graph
- Includes data processing software, USB cable, li-ion rechargeable batteries, AC adapter, and calibration certificate



### Portable Particle Counter Model 3905 & 3910

Small footprint, light-weight portable particle counter available with two different flow rates

- Simultaneous measurements of 6 particle sizes
- 50.0 or 28.3 L/min flow rate
- Small footprint, Stainless enclosure
- Large touch screen LCD displays all measurements simultaneously
- Store up to 10,000 measurements
- PC software allows Remote control, Real-time measuring, and Registering map
- Complete with Quick-start guide, AC adapter, zero filter, Isokinetic probe with 79 inch (2 m) tubing, inlet nozzle, data processing software, memory card, 2 rolls of cleanroom-grade printer paper, Li-ion battery, and calibration certificate

Specifications			
Model	<b>3888</b>	<b>3889</b>	<b>3910 and 3905</b>
Particle Sizes	0.3 / 0.5 / 5.0 µm	0.3 / 0.5 / 1.0 / 3.0 / 5.0 / 10.0 µm	0.3 / 0.5 / 1.0 / 3.0 / 5.0 / 10.0 µm
Flow Rate	0.1 cfm (2.83 L/min)	0.1 cfm (2.83 L/min)	50.0 L/min (3910) or 28.3L/min (3905)
Light Source	Laser Diode	Laser Diode	Laser Diode
Counting Efficiency	50+/-20% @ 0.3 µm	50+/-20% @ 0.3 µm	50+/-20% @ 0.3 µm
Coincidence Loss	Less than 5% at 2,000,000 particles/ft <sup>3</sup>	Less than 5% at 2,000,000 particles/ft <sup>3</sup>	Less than 10% at 500,000 particles/ft <sup>3</sup>
Zero Count Level	Less than 1 count per 5 minutes	Less than 1 count per 5 minutes	Less than 1 count per 5 minutes
Datalogging	10,000 measurements	10,000 measurements	10,000 measurements
Interface	USB	USB	Ethernet, USB, Memory card slot (MMC)
Accessory	Stand (with RS485, wifi, and ethernet)	Stand (with RS485, wifi, and ethernet)	-
Sensor Options	n/a	Temperature, Humidity	Air Velocity, Temperature, Humidity
Enclosure	Molded Plastic	Molded Plastic	Stainless Steel
Power Supply	Li-ion Battery or AC 100 - 240 V	Li-ion Battery or AC 100 - 240 V	Li-ion Battery or AC 100 - 240 V
Dimensions	W8.4" x H3.9" x D2.7"	W8.4" x H3.9" x D2.7"	W7.9" x H8.1" x D7.9"
Weight	1.4 lbs (650 g)	1.4 lbs (650 g)	14.2 lbs (6.44 kg)

# HANDHELD PARTICLE COUNTER MODELS 3888/3889



The standard for cleanroom monitoring and verification

## Features:

- Simultaneously measures and displays 3 or 6 particle sizes (depending on model)
- 4.3 inch color touchscreen
- Store up to 10,000 measurements
- Includes data processing software, USB cable, li-ion rechargeable batteries, AC adapter, and calibration certificate

Specifications	3888	3889
Model	3888	3889
Particle Sizes	0.3 / 0.5 / 5.0 $\mu\text{m}$	0.3 / 0.5 / 1.0 / 3.0 / 5.0 / 10.0 $\mu\text{m}$
Flow Rate	0.1 cfm (2.83 L/min)	0.1 cfm (2.83 L/min)
Light Source	Laser Diode	Laser Diode
Counting Efficiency	50+/-20% @ 0.3 $\mu\text{m}$	50+/-20% @ 0.3 $\mu\text{m}$
Coincidence Loss	Less than 5% at 2,000,000 particles/ft <sup>3</sup>	Less than 5% at 2,000,000 particles/ft <sup>3</sup>
Zero Count Level	Less than 1 count per 5 minutes	Less than 1 count per 5 minutes
Datalogging	10,000 measurements	10,000 measurements
Interface	USB	USB
Accessory	Stand (with RS485, wifi, and ethernet)	Stand (with RS485, wifi, and ethernet)
Option Sensor	n/a	Air Velocity / Temperature, Humidity
Enclosure	Molded Plastic	Molded Plastic
Power Supply	Li-ion Battery or AC 100 - 240 V	Li-ion Battery or AC 100 - 240 V
Dimensions	W8.4" x H3.9" x D2.7"	W8.4" x H3.9" x D2.7"
Weight	1.4 lbs (650 g)	1.4 lbs (650 g)



## NETWORK CONNECTIVITY

By purchasing the optional stand you can easily connect the 3888 or 3889 to your network via RS485, wifi or ethernet for easy remote measuring and monitoring.



Carrying Case

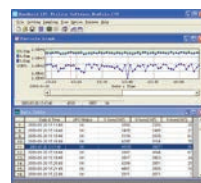

Software Included

## Accessories

- 3888-70: Cradle (Wifi, Ethernet, RS485 communication)
- 3888-12: Battery Charger
- 3888-71: Carrying Case
- 3800-11: Printer Cable
- DPU-S245: Portable Thermal Printer
- TP-5RLPK: Rolled Printer Paper (1 roll)
- TRIPOD-01: Tripod
- 301ADAPT: Intl. Plug Adapter Kit

# PORTABLE PARTICLE COUNTER MODELS 3910/3905

Smallest and lightest portable particle counters

## Features:

- Simultaneous measurements of 6 particle sizes
- Small footprint, Stainless enclosure
- Available in 50.0 or 28.3 L/min flow rates
- Complies with all requirements of ISO 21501-4
- Large touch screen LCD displays all measurements simultaneously
- Store up to 10,000 measurements
- 21 CFR Part 11 compliance
- Complete with quick-start guide, AC adapter, zero filter, isokinetic probe with 79 inch (2 m) tubing, inlet nozzle, data processing software, memory card, 2 rolls of cleanroom-grade printer paper, 1x Li-ion battery, and calibration certificate



Small, Lightweight Unit

Specifications	3910	3905
Model	3910	3905
Particle Sizes	0.3 / 0.5 / 1.0 / 3.0 / 5.0 / 10.0 µm	
Flow Rate	50.0 L/min	28.3L/min
Light Source	Laser Diode	
Counting Efficiency	50+/-20% @ 0.3 µm	
Coincidence Loss	Less than 10% at 500,000 particles/ft <sup>3</sup>	
Zero Count Level	Less than 1 count per 5 minutes	
Datalogging	10,000 measurements	
Interface	Ethernet, USB, Memory card slot (MMC)	
Optional Sensor	Air Velocity, Temperature, Humidity	
Enclosure	Stainless Steel	
Power Supply	Li-ion Battery or AC 100 - 240 V	
Dimensions	W7.9" x H8.1" x D7.9"	
Weight	14.2 lbs (6.44 kg)	

## Optional environmental sensor



Optional Climomaster Environmental Sensor measures airflow, temperature and humidity.

Probe Specifications	6531-2G-P
Model	6531-2G-P
Probe Type	Uni-Directional
Air Velocity	2 to 6000 fpm
Temperature	-4 to 158°F
Relative Humidity	2.0 to 98.0% RH



Climomaster probe for environmental measurements

## Accessories

- |            |   |           |                               |
|------------|---|-----------|-------------------------------|
| 6531-2G-P: | Air Velocity, Temp, RH Probe with 2 m Cable | 3910-10:  | Battery Charger               |
| 3910-01:   | Carrying Case                               | 3910-11:  | Pressure-sensor w/cable       |
| 3910-04:   | Spare Zero Filter                           | CRVAL:    | Validation IQ/OQ Document     |
| 3910-06:   | Standard Inlet (spare)                      | 3900-03:  | Alarm-output cable            |
| 3910-07:   | Stainless Isokinetic Probe (spare)          | TP-5RLPK: | Rolled Printer Paper (1 roll) |
| 3910-08:   | AC adapter (spare)                          |           |                               |
| 3910-09:   | Spare Li-ion Battery                        |           |                               |

# HANDHELD CONDENSATION PARTICLE COUNTER MODEL 3800



Optimal screening tool for nano size particles

## Features:

- 0.015 micron (15nm) minimum sensitivity
- Handheld and Lightweight Aerosol Research Instrument
- Store up to 10,000 measurements
- PC interface with USB and software for real-time measurements and display time fluctuation graph
- Complete with zero filter, data processing software, USB cable, alcohol bottle, 6 pc. AA batteries, carrying case, and calibration certificate

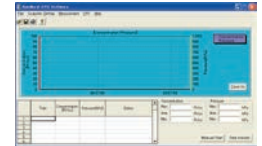

Software Included

## Measuring Principle

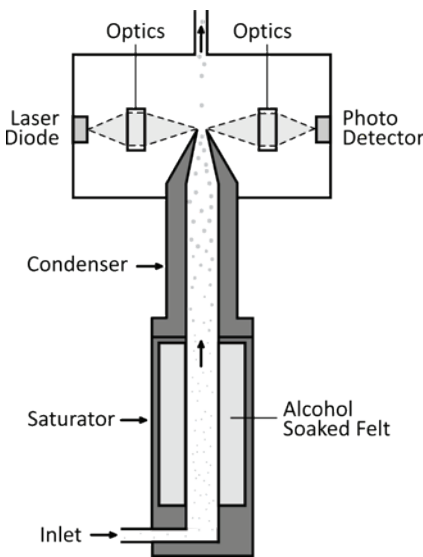

Specifications	
Model	3800
Measuring Object	Airborne Particle Matter
Particle Sizes	0.015 to 1.0 $\mu\text{m}$
Flow Rate	0.7 L/min
Light Source	Laser Diode
Counting Efficiency	100% @ 0.05 $\mu\text{m}$ More than 50% @ 0.015 $\mu\text{m}$
Coincidence Loss	Less than 5% at 100,000 particles/cm <sup>3</sup>
Zero Count Level	< 1 count per 5 minutes
Alcohol Supply	Isopropyl Alcohol
Datalogging	10,000 measurements
Interface	USB
Power Supply	6 x AA Batteries or AC 100 - 240 V
Dimensions	W4.7" x H11.0" x D5.1"
Weight	3.3 lbs (1.5 kg)

## Applications



Checking Worker Exposure to Airborne Contaminants



Leakage Testing



Engine Exhaust Testing

## Accessories

- |                                   |   |
|-----------------------------------|---|
| 3800-01: AC Adapter               | 3800-07: Communication Cable to PC      |
| 3800-02: Zero Filter              | 3800-08: Carrying Case                  |
| 3800-03: Alcohol Bottle           | 3800-11: Printer Cable                  |
| 3800-04: Storage Cap              | DPU-S245: Portable Thermal Printer      |
| 3800-05: Alcohol Cartridge        | TP-5RLPK: Rolled Printer Paper (1 roll) |
| 3800-06: Spare Felt and Wire Mesh |   |

# REMOTE PARTICLE SENSOR WITH ANALOG OUTPUT

## 2-channel remote particle sensors for facility monitoring applications

Kanomax particle sensors with analog output are designed to fit into your existing monitoring system, or they can be used as an individual unit to monitor a critical area when connected to an alarm or controller. The Kanomax particle sensor is available with a 1.0 CFM flowrate and also comes in two different ranges: 0.3 and 0.5 microns or 0.5 and 5.0 microns.

### Features:

- Light scattering particle sensor
- 1.0 cfm flow rate (28.3 lpm)
- Analog output and RS485 Modbus capability makes it easy to integrate into existing systems
- 0.3 or 0.5 micron sensitivity
- Compact body with stainless enclosure
- Fully compatible with the Kanomax Cleanroom Monitoring System as well as third party existing systems



Specifications	
Model	3718-A
Measuring Object	Airborne Particle Matter
Particle Sizes	0.3 / 0.5 $\mu\text{m}$ 0.5 / 5.0 $\mu\text{m}$
Flow Rate	1.0 cfm (28.3 L/min) *External vacuum source is required
Light Source	Laser Diode
Counting Efficiency	50% @ 0.3 $\mu\text{m}$ 50% @ 0.5 $\mu\text{m}$
Coincidence Loss	Less than 10% at 500,000 particles/ft <sup>3</sup>
Zero Count Level	< 1 count per 5 minutes
Interface	RS485 (Modbus protocol) & 4-20mA
Enclosure	Stainless Steel
Power Supply	9 - 28V (AC adapter supplies 12V)
Dimensions	W5.2" x H3.1" x D3.7"
Weight	2.2 lbs (1.0 kg)

### Applications:

- Cleanroom Facility Monitoring
- Food Industry
- Aerospace
- Hospital Surgical Rooms

**Example Configuration:** Shows 6 sensors connected to datalogger via the 4-20 mA output. It's easy to connect them to a datalogger or any other device that will accept an analog signal. Note that a vacuum source is required for the sensors.

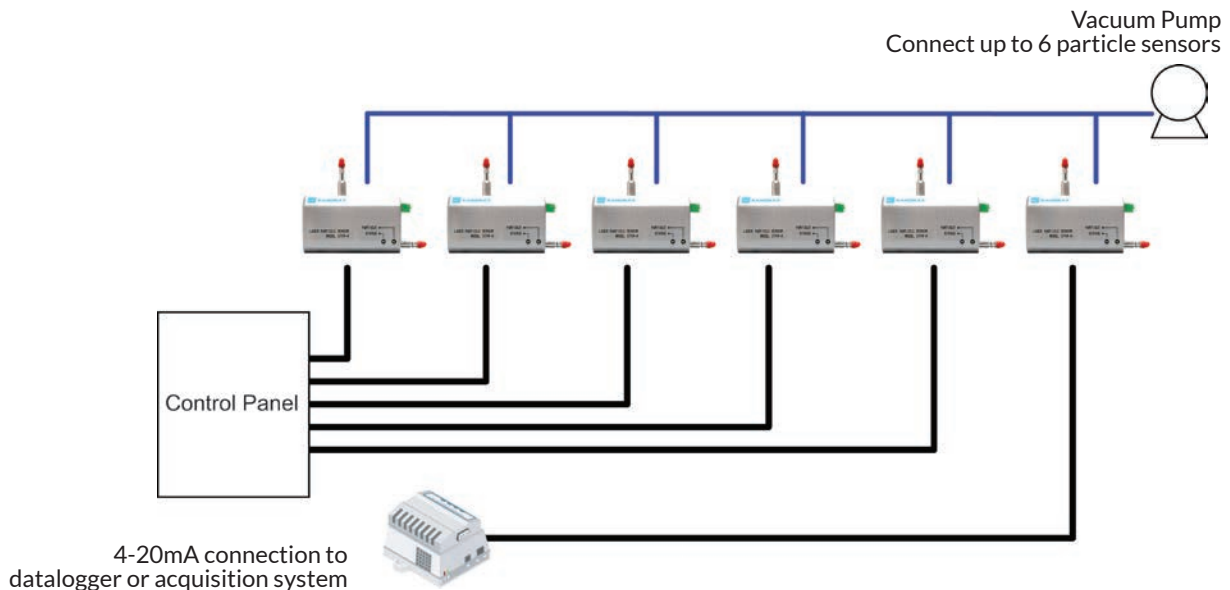

### Accessories

- |           |   |            |                              |
|-----------|---|------------|------------------------------|
| 3910-04:  | Spare Zero Filter                                   | 3716A-21:  | Converter Connecting Cable   |
| 3716A-07: | Isokinetic Suction Probe                            | 3716A-40:  | Spare Configuration Software |
| 3716A-20: | Product Configuration Adapter (USB-RS485 Converter) | 3716A-280: | Vacuum Pump                  |

# CLEANROOM MONITORING SYSTEM

## The all-in-one monitoring solution

The Kanomax Cleanroom Monitoring System (CRMS) provides an automated means to monitor and gather airborne particle counts and other parameter levels in controlled environments. The CRMS allows users to perform a variety of functions from a PC, including changing alarm settings and viewing particle count concentrations.

### Features:

- Compact stainless enclosure with sensors
- Systems can be custom-built for multi-parameter measurements including particle count, air velocity, temperature, humidity, and differential pressure
- Multi-function, user-friendly monitoring software
- 1 PC system controls up to 128 sensors
- Alarm outputs: warning light, on-screen, or pager notification
- No system down-time: each sensor is replaceable for repair and recalibration



## Particle Sensors



### Features:

- Light scattering particle sensor
- Durable stainless enclosure is easy to sanitize during whole facility cleaning

Specifications	
Model	3714
Measuring Object	Airborne Particle Matter
Particle Sizes	0.3 / 0.5 $\mu\text{m}$
Flow Rate	0.1 cfm (2.83 L/min) *External vacuum source is required
Light Source	Laser Diode
Counting Efficiency	50% @ 0.3 $\mu\text{m}$
Coincidence Loss	Less than 5% at 1,000,000 particles/ft <sup>3</sup>
Zero Count Level	< 1 count per 5 minutes
Interface	RS485
Enclosure	Stainless Steel
Power Supply	DC24V (Supplied from the 3770)
Dimensions	W5.0" x H2.8" x D1.6"
Weight	1.1 lbs (500 g)



### Features:

- Light scattering particle sensor
- 1.0 cfm flow rate (28.3 lpm)
- Analog output and RS485 Modbus capability makes it easy to integrate into existing systems

Specifications	
Model	3718-A
Measuring Object	Airborne Particle Matter
Particle Sizes	0.3 / 0.5 $\mu\text{m}$
Flow Rate	1.0 cfm (28.3 L/min) *External vacuum source is required
Light Source	Laser Diode
Counting Efficiency	50% @ 0.3 $\mu\text{m}$
Coincidence Loss	Less than 5% at 500,000 particles/ft <sup>3</sup>
Zero Count Level	< 1 count per 5 minutes
Interface	RS485 & 4-20mA
Enclosure	Stainless Steel
Power Supply	9 - 28V
Dimensions	W5.9" x H4.7" x D3.9"
Weight	3 lbs (1.5 kg)

## Distributors



### Features:

- Supplies data communication and power to sensors via RS485
- 1 unit connects up to 8 sensors

Specifications	
Model	3770
# of Channels	8
Interface	RS485
Power Supply	AC 85 to 132 V or AC 170 to 267 V
Dimensions	W11.8" x H3.9" x D7.9"
Weight	6.6 lbs (3 kg)

## Interface Box



### Features:

- Interfaces with multiple sensor types
- Converts analog input to digital
- Supplies power to the sensor

Specifications	
Model	3772-02
Input	4 to 20 mA / 0 to 1 V / 1 to 5 V
Output	RS485
Power Supply	DC24V (Supplied from the 3770)
Dimensions	W5.5" x H3.1" x D1.6"
Weight	1.1 lbs (500 g)



with Differential Pressure Sensor

## Cleanroom Monitoring Software

### Features:

- Continuous monitoring and data processing software
- Remote monitoring via LAN
- Multi-function: Map display at a glance, Real-time graph, Maintenance Indication, and Data table



Map

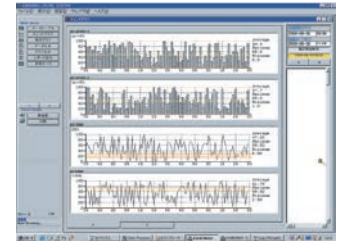

Trend Graph

## System Examples

### Industrial Cleanroom

Semiconductor, HDD, Flat Panel Display, Electronics

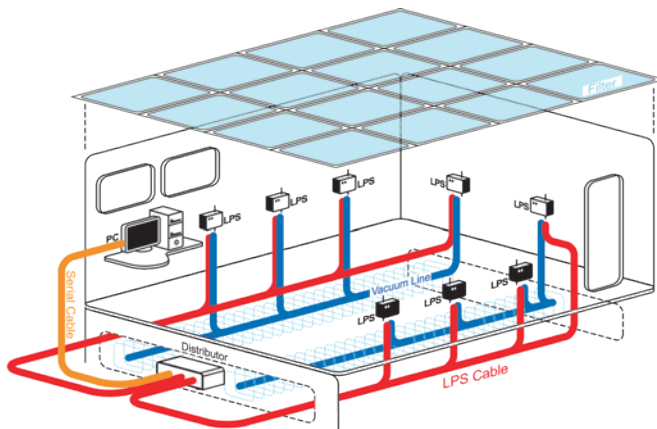

### Bio-medical Cleanroom

Food, Pharmaceutical, Hospital surgical rooms

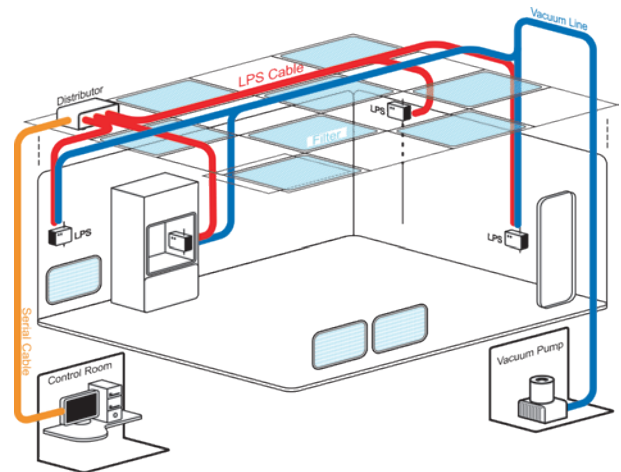

# INDOOR AIR QUALITY MONITORS

## ■ Applications



Hospitals and Elderly Care Facilities Monitor



Green building rating system  
IEQ performance testing

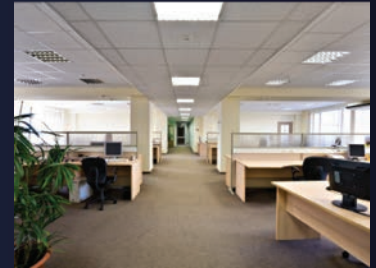

Indoor Air Quality Investigation

**VENTILATION TESTING**

**THERMAL COMFORT CONTROL**

**OCCUPATIONAL HEALTH CONTROL**

**MONITORING TOXIC GAS**





# HANDHELD IAQ MONITOR MODEL 2212

## Multi-function indoor air quality monitor

### Features:

- Simultaneous measurements of CO, CO<sub>2</sub>, temperature, and relative humidity
- Calculates dew point, wet bulb temperature, absolute humidity, humidity ratio, and % outside air
- Store up to 1500 measurements
- Easy user self calibration
- Easy replacement of probe
- PC interface with RS232C or USB and software for real-time measurements and downloading data to your PC
- Complete with probe with 79 in (2m) cable, probe stand, calibration cap & connection tube, data processing software, RS232C cable, 6 pcs. AA batteries, carrying case, and NIST-Traceable calibration certificate



Specifications	
Model	2212
Carbon Monoxide (CO)	0 to 500 ppm
Accuracy	+/- 3% of reading
Carbon Dioxide (CO <sub>2</sub> )	0 to 5000 ppm
Accuracy	+/- 3% of reading
Temperature Range	-4 to 140 F (-20 to 60 C)
Accuracy	+/- 1.0°F (0.5°C)
Relative Humidity Range	2.0 to 98.0 %RH
Accuracy	+/- 2% of reading
Interface	RS232C
Datalogging	1500 measurements
Analog Output	0 to 1 V *Option
Power Supply	6 x AA Batteries or AC Adapter
Dimensions	W3.4" x H7.4" x D1.6"
Weight	0.9 lbs (400 g)

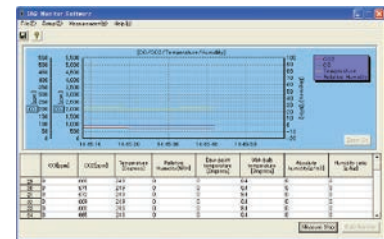

Software Included

### Accessories

- 6113-02: AC Adapter
- 2211-09: Analog Output
- DPU-S245: Portable Thermal Printer
- 6000-03: Printer Cable for DPU-S245
- TP-5RLPK: Rolled Printer Paper (1 roll)

### Indoor Comfort

Comfort is very subjective and will vary from one individual to the next, but ASHRAE Standard 55 provides guidelines for a "comfort zone" that most people will feel comfortable in. This comfort zone is derived from both temperature and humidity and varies depending on the season. See the chart to the right for details. The 2212 IAQ Monitor from Kanomax can measure both parameters simultaneously indicating if changes are needed to make a building's occupants comfortable.

The monitor can also check CO<sub>2</sub> levels and determine the rate of exchange, or the percentage of outside air, being introduced to a building per ASHRAE Standard 62. Controlling the rate of exchange with the HVAC system is critical to ensuring occupant well-being. Too much CO<sub>2</sub> build-up can cause lethargy and make it difficult for individuals to concentrate. Too much outside air may also be harmful if it's introducing external pollutants to the environment.

The 2212 is a great tool for IAQ investigation and spot checks to ensure an indoor environment remains within desired levels to maintain occupant health and comfort. The ability to measure all of these parameters in a single instrument simplifies the labor involved and eliminates the need to purchase and learn multiple instruments.

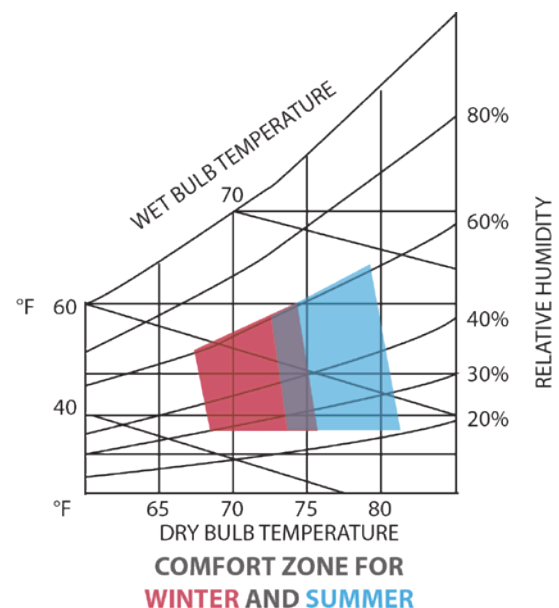

# GASMASTER HANDHELD GAS MONITORS



CO, CO<sub>2</sub>, ammonia, ozone, VOC etc. More than 20 gases

## Features:

- Simultaneous measurements of gas concentration, temperature, and humidity
- Model 2710 is a simple, easy-to-use, low-cost monitor
- Model 2750 has data logging function and a USB interface for PC communication
- The gas monitor is fully compatible with all gas sensors
- Sensor heads for handheld units are interchangeable without recalibration of main unit



Specifications	2710	2750
Model	2710	2750
Measurement Units	ppm or mg/m <sup>3</sup>	ppm or mg/m <sup>3</sup>
T/H* Sensor	Available as option	Available as option
On-board alarm	—	○
Remote Sensor	○	○
Datalogging	—	8,188 measurements
Interface	—	USB
Analog Output	—	0 to 5 V
Power supply	Li-ion battery pack or AC adapter	Li-ion battery pack or AC adapter
Dimensions	W7.4" x H4.8" x D2.1"	W7.4" x H4.8" x D2.1"
Weight	1.0 lbs (460 g)	1.0 lbs (460 g)

\* Temperature and Humidity



## Gas Sensor Heads

Gas Sensor Specifications	Range (ppm)	Accuracy	Resolution
Gas Sensor Heads			
Ammonia	0 to 100	<+/-5 ppm + 15%	0.1 ppm
Ammonia	0 to 1000	<+/-0.5 ppm + 10%	1 ppm
Carbon monoxide	0 to 100	<+/-1 ppm (0 to 10 ppm) <+/-10% (10 to 100 ppm)	0.1 ppm
Carbon monoxide	0 to 1000	<+/-2 ppm + 15%	1 ppm
Carbon dioxide	0 to 2000	<+/-10 ppm + 5%	1 ppm
Hydrogen	0 to 5000	<+/-10 ppm + 10%	1 ppm
Hydrogen sulphide	0 to 10	<+/-0.05 ppm (0 to 0.5 ppm) <+/-10% (0.5 to 10 ppm)	0.01 ppm
Methane	0 to 9999	<+/-20 ppm + 15%	1 ppm
Ozone	0 to 0.150	+/- 0.005 ppm	0.001 ppm
Nitrogen dioxide	0 to 1.0	<+/-0.02 ppm (0 to 0.1 ppm) <+/-10% (0.2 to 1 ppm)	0.001 ppm
NMHC	0 to 25	<+/-0.1 ppm + 10%	0.1 ppm
Sulphur dioxide	0 to 10	<+/-0.05 ppm (0 to 0.5 ppm) <+/-10% (0.5 to 10 ppm)	0.01 ppm
Formaldehyde	0 to 10	<+/-0.05 ppm (0 to 0.5 ppm) <+/-10% (0.5 to 10 ppm)	0.01 ppm
VOC	0 to 25	<+/-0.1 ppm + 10%	0.1 ppm
VOC	0 to 500	<+/-5 ppm + 10%	1 ppm
VOC PID	0 to 20	<+/-0.02 ppm + 10%	0.01 ppm
VOC PID	0 to 1000	<+/-0.2 ppm + 10%	0.1 ppm

## Accessories

- KMTRH: Temperature/Relative Humidity Sensor
- KMENC: Protective Enclosure
- KMR10: Remote Sensor Kit
- KMR36: Replacement Li-ion Battery
- KMR40: Carrying Case
- KMR42: Calibration Kit

## Compatible for Indoor Air Quality Survey

- Carbon Monoxide (CO)
- Carbon Dioxide (CO<sub>2</sub>)
- Multi-gas sensor (MS1 and MS2)
- Ozone (O<sub>3</sub>)
- Sulphur Dioxide (So<sub>2</sub>)
- Formaldehyde (CH<sub>2</sub>O)
- Volatile Organic Compounds (VOC)

## Compatible for Environmental Survey

- Nitrogen Dioxide (NO<sub>2</sub>)
- Hydrogen Sulphide (H<sub>2</sub>S)
- Sulphur Dioxide (So<sub>2</sub>)
- Carbon Monoxide (CO)
- Carbon Dioxide (CO<sub>2</sub>)
- Volatile Organic Compounds (VOC)
- Ozone (O<sub>3</sub>)
- Ammonia (NH<sub>3</sub>)
- Non Methane Hydrocarbon (NMHC)

# HANDHELD ODOR MONITOR

## Highly sensitive; 3 models for various applications

Handheld Odor Meter is the most popular simplified tool for odor analysis, which indicates the relative strength and odor classification numerically by comparing the odor gas and purified air.

### Features:

- Numerical value for relative strength of smell
- Numerical value for classification of smell
- Handheld Odor meter is ideal for Before and After applications, such as air purification and cleaning service.
- Real-time sampling mode displays odor change continuously
- Memory sampling mode saves data based on the selected sampling rate. (up to 32732 data, 511 files)
- Battery operated with 7 hrs continuous usage



### Applications:

#### OMX-SRM

- Finding odor source at factories, incinerator, plants, or effluent treatment facility

#### OMX-ADM

- Evaluation for deodorizing at hospitals or nursing homes
- Suitable for putrid odor such as ammonia

#### OMX-TDM

- TVOC measurement for monitoring IAQ condition

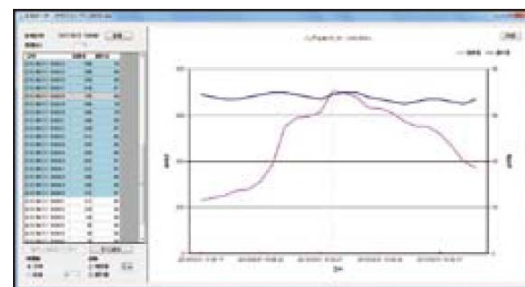
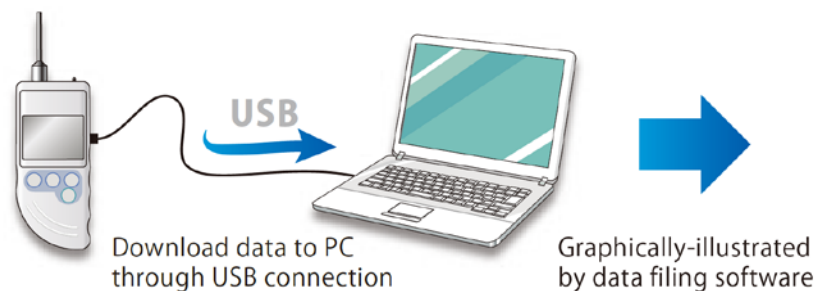

Specifications	OMX-SRM	OMX-ADM	OMX-TDM
Model	OMX-SRM	OMX-ADM	OMX-TDM
Detection Method	Two Semiconductor Gas Sensors		
Sampling Method	Continuous Sampling with Built-in Air Pump		
Object Gas	Ethanol, Acetone, Hydrogen, etc	Hydrogen, Sulfide, Methyl Mercaptan, Ammonia, etc	TVOC (Toluene), etc
Odor Strength Level	0.0 to 999	0 to 999	0.0 to 9999 (µg/m3)
Classification	Class 0 to 90	Odor Intensity 2.5 to 5.0	n/a
Power Supply	4 x AA batteries or AC adaptor *Battery life for continuous measurement is approx. 7 hours		
Memory Capacity	Up to 32732 data		
Storage Temperature	0 to 40°C (32 to 104 °F) * No condensation		
Operating Temperature	-10 to 50°C (14 to 122 °F) * No condensation		
Dimensions	74 (W) x 167.5 (L) x 35 (H) mm		
Weight	250g (without batteries)		

# DUST MONITORS

## ■ Applications



Monitoring worker exposure to airborne contaminants



Indoor Air Quality Assessments





### Piezobalance Dust Monitor Model 3521 / 3522

- Measures PM 10, Respirable, or PM 2.5 particle matters
- Real-time measurements of dust concentration
- Data logging up to 500 measurements
- Simple cleaning mechanism for easy maintenance
- Complete with data processing software, RS232C cable, cleaning kit, Ni-MH battery pack, AC adapter, carrying case, and calibration certificate



### Digital Dust Monitor Model 3443

- Measures PM 10 particle matters
- Compact and Lightweight unit
- Analog output controls other devices
- Data logging up to 100,000 measurements
- PC interface with USB and software for downloading data to your PC
- Complete with rubber protector, shoulder strap, data processing software, USB cable, AC adapter, 2 pcs. LCD protective sheet, rubber cap, 2 pcs. filter, and calibration certificate

## Specifications

Model	3521 / 3522	3443
Measuring Method	Piezobalance	Light Scattering
Particle Size Range	0.1 to 10 µm (Model 3521) 0.1 to 2.5 µm (Model 3522)	0.1 to 10 µm
Measuring Range	0.01 to 10.00 mg/m <sup>3</sup>	0.001 to 10.000 mg/m <sup>3</sup>
Flow Rate	1.0 L/min	1.0 L/min
Datalogging	500 measurements	100,000 measurements
Interface	RS232C	USB
Analog Output	n/a	0 to 1 V / Pulse / Alarm
Power Supply	Ni-MH Battery or AC 100 - 240 V	6 pcs. AA Batteries or AC 100 - 240 V
Dimensions	W2.6" x H7.1" x D5.9"	W6.7" x H2.7" x D4.3"
Weight	3.9 lbs (1.75 kg)	2.9 lbs (1.3 kg)

## Optimal tool for monitoring oil mist

### Features:

- Measures PM 10, Respirable, or PM 2.5 particle matters, such as dust, oil mist, fumes, and soot
- Real-time measurements of dust concentration
- Data logging up to 500 measurements and data may be reviewed on screen or printed
- PC interface with RS232C and software for downloading data to your PC
- Easy operation ; no special training required
- Simple cleaning mechanism for easy maintenance
- Includes data processing software, RS232C cable, cleaning kit, Ni-MH battery pack, AC adapter, carrying case, and calibration certificate



Specifications		
Model	3521	3522
Measuring Method	Piezobalance	
Particle Size Range	0.1 to 10 µm	0.1 to 2.5 µm
Measuring Range	0.01 to 10.00 mg/m <sup>3</sup>	
Flow Rate	1.0 L/min	
Datalogging	500 measurements	
Interface	RS232C	
Power Supply	Ni-MH Battery or AC 100 - 240 V	
Dimensions	W2.6" x H7.1" x D5.9"	
Weight	3.9 lbs (1.75 kg)	

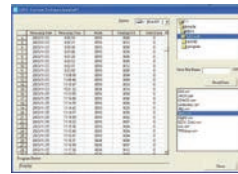

Software Included

### Accessories

- 3521-01: Rechargeable Battery Pack
- 3521-02: Carrying Case
- 3521-03: 10 µm Impactor Nozzle (for 3521)
- 3521-04: 4 µm Impactor Nozzle (for 3521)
- 3521-05: AC Adapter
- 3521-06: Cleaning Sponges (3 pieces)
- 3521-07: Cleaning Fluid
- 3521-08: RS-232C Communication Cable to PC
- 3521-20: Printer Cable
- DPU-S245: Portable Thermal Printer
- TP-5RLPK: Rolled Printer Paper (1 roll)

## Dust Measuring Methods

### ■ Piezobalance Method

An air sample enters the system, it travels through the impactor, which captures and removes larger particulates away from the sample. Smaller particulates become electrically charged and deposited on the piezo-crystal. The total mass of the deposited particulates affects the piezo-crystal's frequency. Since the change in frequency is proportional to the mass of the particulates, the actual weight of the particulates is obtained.

Since some particle matters such as oil mist absorb lasers, the Piezobalance dust monitor would be ideal (the light scattering method would not give correct measurements).

### ■ Light Scattering Method

When a laser hits particle matter, light scattering occurs. A dust monitor collects the amount of scattering light and calculates the mass concentration in proportion to the scattering light. Mass concentration is based on the density of particle matter, thus gravimetric sampling is required if the density is unknown.

Applications for light scattering dust monitor include Indoor air quality investigations, Point source monitoring, and Personal exposure monitoring.

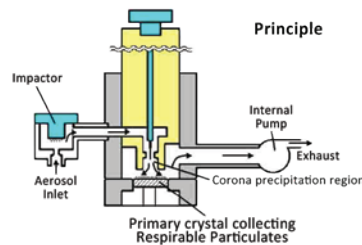

#### Applications:

- Monitoring milling operation
- Monitoring honing
- Monitoring boring operation



Monitoring Milling Operation



Monitoring Welding Operation

# DIGITAL DUST MONITOR MODEL 3443

## Monitor particles in industrial environments

### Features:

- Measures PM 10 particle matters, such as dust, fumes, and smoke
- Real-time and long term measurements of dust concentration
- Compact and Lightweight unit
- PC interface with USB cable and software for downloading data to your PC
- Analog output controls other devices
- Data logging up to 100,000 measurements and displays MIN / MAX / AVG and Timing graph for review
- Complete with rubber protector, shoulder strap, data processing software, USB cable, AC adapter, 6 pcs. AA batteries, 2 pcs. LCD protective sheet, rubber cap, 2 pcs. filter, and calibration certificate

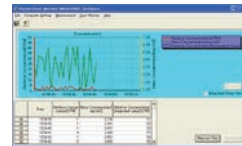

Software Included



With Rubber Protector

Specifications	
Model	3443
Measuring Method	Light Scattering
Particle Size Range	0.1 to 10 µm
Measuring Range	0.001 to 10.000 mg/m <sup>3</sup>
Flow Rate	1.0 L/min
Datalogging	100,000 measurements
Interface	USB
Analog Output	0 to 1 V / Pulse / Alarm
Power Supply	6 pcs. AA Batteries or AC 100 - 240 V
Dimensions	W6.7" x H2.7" x D4.3"
Weight	2.9 lbs (1.3 kg)

### Accessories

- 3442-01: Analog Output Cable
- 3442-02: Rubber Protector
- 3442-04: LCD Protective Sheet
- 3442-05: Carrying Case
- 3442-10: Rubber Cap
- 3431-03: Filter (10 pc)
- 6113-02: AC Adapter
- TRIPOD-01: Tripod

# CEGRIT AUTOMATIC FLYASH SAMPLER

## Isokinetic sampling for particle emission testing

With no moving parts, each CEGRIT sampler collects a sample from one point in the boiler duct. Operating on duct vacuum to drive its atmospheric-air ejector, the CEGRIT maintains near-isokinetic sampling to keep collecting unbiased sample as boiler load and duct vacuum vary.

### Features:

- Operates continuously with no moving parts
- High efficiency sampling rate for fine pulverized dust
- Industrial construction
- Cyclone removes to facilitate periodic cleaning
- Two manometer tap points to monitor draft pressure

### Applications:

- All combustion or other processes where airborne particle emission occur
- Smoke and particle emissions or grit burdens from boiler stacks
- Carbon determination in Fly ash
- Incinerator emission compliance

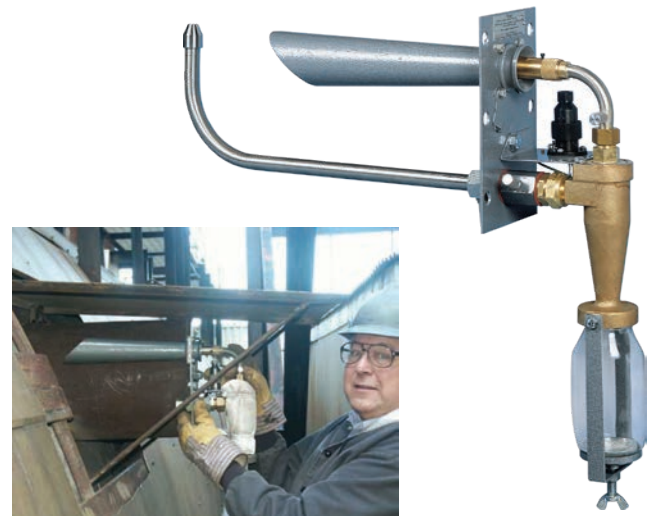

### Accessories

- C8406: Probe (2 m)
- C8408: Probe (3 m)
- C8407: Probe Extension (10 ft)
- C3101: Inlet Nozzle 1/2" (12.7 mm)
- C3102: Inlet Nozzle, 5/8" (15.9mm)
- C3103: Inlet Nozzle, 3/4" (19.0 mm)
- C3104: Inlet Nozzle, 3/8" (9.5 mm)
- C5019: Heater Jacket, 100W, 240 Volt
- C5020: Heater Jacket, 100W, 110 Volt



# SOUND AND VIBRATION METERS

## ■ Applications



Environmental noise measurement



Noise exposure measurement



Industrial vibration testing



# SOUND LEVEL METER MODEL 4431



## Precision sound level meter with 0-dB function

The Kanomax Sound Level Meter is designed to be compact, lightweight and easy to use. It complies with the type 2 ANSI S1.4 1983 standard, and has an innovative, unique 0-dB feature that eliminates the self-noise of the microphone. This technology extends the lower limit of the measurement range to lower than 0 dB-SPL.

### Features:

- *Lightweight and compact design*
- *Equipped with highly sensitive electret condenser microphone*
- *Large 4 digit display with 0.1 dB resolution with backlighting and analog bar graph*
- *Add additional functions with the program cards*
- *Includes SD card for data storage, windshield, carrying case, AA batteries, hand strap, and calibration certificate*



Optional program cards give you the flexibility to add additional functions as needed

Specifications	
Model	4431
Parameters	Lp, LA, LAeq, LAE, LAmax, LAmin, LAN, Lpeak, LA <sub>Tm5</sub>
Ranges	A: 28 - 130 dB, Z 39 - 130 dB
Weighting	A, C and Z
Time Response	Fast or Slow
Microphone	TYPE 7146nl (-28dB, Stand-alone -26dB)
Standards	Type 1 (4432) or Type 2 (4431) standards for ANSI S1.4 1983, IEC 61672-1
Power Supply	4 AA Batteries or optional AC Adapter (Battery life: approx. 9 hours)
Size & Weight	W3.4" x H12.9" x D1.9", Approx 1 lb.

### Accessories

AC-1026:	AC Adapter
ACBC-0046-3:	Microphone Cable (3m)*
ACBC-0046-5:	Extension Cable (5m)*
ACBC-0071:	BNC-Pin Cable
ACNA-0038W:	Data Processing Software
ACNA-0038:	Program Card (1/1, 1/3 Octave Analyzer)
ACNA-0038F:	Program Card (FFT Analyzer)
ACNA-0038R:	Program Card (Real Sound Recording)
ACNA-0333:	Tripod

\*Additional cable lengths available

# VIBRATION METER MODEL 4200

## Compact, easy-to-use vibration meter

The Kanomax Vibration Meter is designed to be compact, lightweight and easy to use. The magnetic accelerometer attaches easily to machinery for increased accuracy and precise operation. It's the perfect tool to diagnosis problematic vibrations with your industrial machinery or manufactured products.

### Features:

- *Compact size maximizes technician mobility*
- *Magnetic accelerometer increases measuring accuracy and ease-of-use*
- *Includes meter, accelerometer with cable and magnet, contact pin, 2 x AAA batteries, carrying case, and calibration certificate*

Specifications	
Measurement Range	
Acceleration	0.02 to 200 m/s <sup>2</sup> RMS
Velocity	0.02 to 200mm/s RMS
Displacement	2 to 2000 μm EQp-p
Frequency Range	
Acceleration	3Hz to 10kHz
Velocity	10Hz to 1kHz (Compliant with JIS B0907-1989)
Displacement	10 to 400Hz
Readings	RMS, Peak, EQ Peak, EQ Peak-to-Peak
Output	
AC Output	1Vrms (Full Scale)
Headphone Output	Portable Headphones w/Volume function
Interface	RS232C
Operating Environment	
Temperature	-10 to 50°C
Humidity	30% to 90% (no condensing)
Power Supply	2 x AAA batteries or AC adapter
Dimensions & Weight	5.7"(H)x1.9"(W)x0.9"(D) Approx. 4.6 oz.



### Accessories

AC-1046:	AC Adapter
AC7812B:	Pickup w/ Preamp
ACPV-0148:	Spare Magnet
ACPV-5050:	Strong Magnet
ACNA-0134:	Auscultation Rod
ACSS-22M:	Stud
ACBC-0071:	BNC-Pin Cable
ACBC-0116-3:	Extension Cable 3m*
ACNA-0116:	Data Processing Software
ACBC-0026:	Communication Cable (RS232)

\*Additional cable lengths available

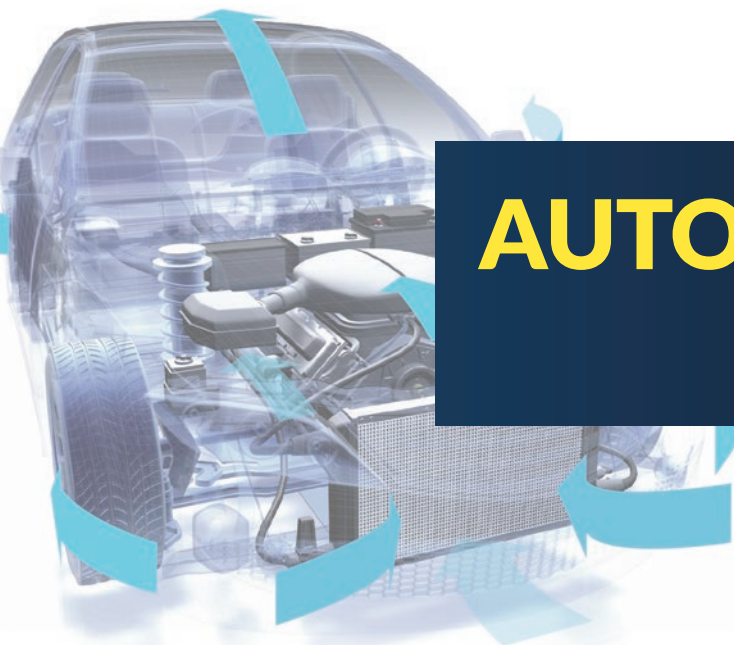

# AUTOMOTIVE TESTING INSTRUMENTS

## AMENITY MANIKIN SYSTEM

### Cabin Comfort Test Rig

Kanomax Amenity Manikin System is a solution for precise interior cabin comfort evaluation. The system measures parameters; air velocity, temperature, humidity, and radiant heat; which relate to human comfort level. One mannequin equips more than 120 sensors all over its surface and provides sophisticated measurement.

#### Features:

- 4 mannequins measure simultaneously; understanding the entire cabin
- Wireless connection brings easy operation
- Graphical software for both real-time measurement and data retrieval
- Excel compatible data output as well as saved graphical data for review



Amenity Manikin

#### Sensor Allocations by Part

	Air Velocity	Temperature	Humidity	Radiant Heat
Head	4	12	1	3
Torso	12	33	0	5
Lower Body	20	33	1	4
<b>Total</b>	<b>36</b>	<b>78</b>	<b>2</b>	<b>12</b>

#### Mannequin Specifications

Height	Approx. 5'6" (170 cm)
Weight	90 lbs (40 kg)
Material	Plastic (FRP)

#### Sensor Specifications

Air Velocity Ranges	0.10 to 5.00 m/s
Accuracy	0.05 m/s
Temperature Ranges	30 to 100°C
Accuracy	+/- 3.0°C
Humidity Ranges	3 to 95% RH
Accuracy	+/- 3% RH
Radiant Heat Ranges	0 to kw/m <sup>2</sup>
Accuracy	+/- 7%
Wavelength	0.3 to 40 μm

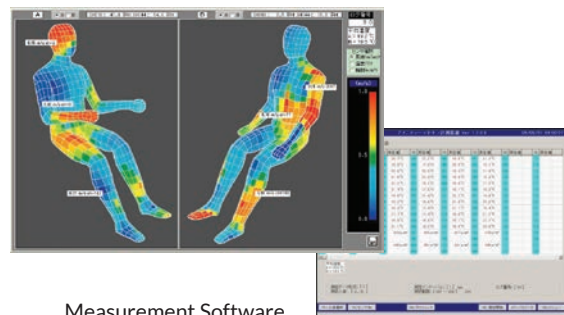

Measurement Software

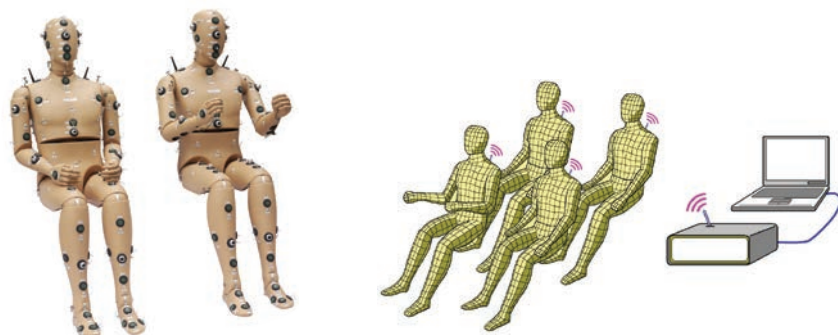

# STEAM GENERATOR

## Vehicle de-mister testing instrument

The Kanomax Steam Generator is specifically designed for automobile de-mister testing. This instrument fills the automobile cabin with steam to create a humid environment, increasing the fog that accumulates on the windshield. The de-mister can then be tested in accordance with JIS D 4502/4504-1994, ISO 3470-1989(E), EEC 661, and SAE J953 standards.

### Features:

- Generates up to 390g per hour
- Conducts tests in accordance with JIS D 4502/4504-1994, ISO 3470-1989(E), EEC 661, and SAE J953 standards.
- Steam volume generation up to 1 gallon

Specifications	
Steam Generation	65 to 390 g/hour
Heat Loss	Less than 75W
Steam Volume	1 gallon (3.785 liters)
Heater Capacity	Up to 500W at AC100V
Nozzle	Inner diameter of 15 mm x 100 mmL
Fan Airflow	0.05 to 0.1 m3/min at 49 Pa
Standards	JIS D 4502/4504-1994
	ISO 3470-1989(E)
	EEC 661
	SAE J953



# CABIN LEAKAGE TESTER

## Cabin comfort test rig

Leakage testing is performed by pressurizing or depressurizing the vehicle cabin. The tester measures the changes in cabin pressure. The control unit consists of a manometer and pressure transducers. The manometer detects the leakage flow, which is calculated by measuring the nozzle pressure relative to static pressure. The tester controls an adjustable fan to maintain static test pressure.

### Features:

- Automatic Pressure Control
- Negative Pressure Testing
- Features High Accuracy Manometer

Specifications	
Airflow Ranges	100 to 500 m3/hour
Maximum Static Pressure	300 Pa
Nozzle Diameter	41 or 69 mm
Power Supply	AC100V, 20A, Single phase
Standards	JIS D1622
	JIS B 8330





**KANOMAX**  
*The Ultimate Measurements*

TO PLACE AN ORDER CONTACT US AT:

**Kanomax USA, Inc.**

P.O. Box 372

219 US Highway 206

Andover, NJ 07821 USA

**TEL: 1-800-247-8887 (USA) / 1-973-786-6386**

**EMAIL: [sales@kanomax-usa.com](mailto:sales@kanomax-usa.com)**

**URL: [www.kanomax-usa.com](http://www.kanomax-usa.com)**



Distributed by:



Copyright © 2020 KANOMAX USA, Inc.

Document revision v5. Revision made 03-01-2020.

All specifications subject to change without prior notice.